

ASSEMBLY AND OPERATING INSTRUCTIONS

E-DRIVE OPTIMA MOTORISED WHEEL

Versions: single, dual, twin



TENTE

BETTER MOBILITY. BETTER LIFE.

Table of contents

- Foreword 4**
 - Supporting documents 4
 - Markers in the text 4
 - Copyright 4
 - Manufacturer’s address 4
 - Documentation Officer 4
- Safety 5**
 - Use as intended 5
 - Note on residual risks 5
 - Qualification of assembly personnel 5
 - Qualification of connection personnel 5
 - Qualification of operating personnel 5
 - Personal protective equipment 5
 - Basic safety instructions 5
 - Markers associated with hazard notes 6
 - Markers associated with equipment damage notes 6
- Transport 6**
- Description 7**
 - Description of use 7
 - Composition of the E-Drive optima set 7
 - Optional accessories 7
- Assembly 8**
 - Cautionary note 8
 - Nameplate 8
- Assembly of the control handle and the assist grip 8**
 - Assembly on a flat surface 8
 - Assembly on a tube 8
 - Recommended positions of the mounting plate (Optima or Optima Dual version) 10
 - Recommended positions of the mounting plates (Optima Twin version) 10
 - Unpacking the device(s) 11
- Mounting and connecting the unit 11**
 - Equipment needed 11
 - Mounting the drive unit 11
 - Connecting the drive unit 11
 - Optima version: 1 handle + 1 motor 12
 - Optima Dual version: 2 sets of handles + 1 motor 12

Optima Twin version: 1 handle + 1 cable between the motors + 2 batteries + 2 motors	12
Cautionary note.....	12
Operation	13
General information.....	13
Safety features	13
Start-up and operation After ensuring that all components of the E-Drive optima are correctly connected and after setting the operating parameters:	13
Battery and brake warning information	14
Battery alert information	14
Braking information	14
Cleaning and maintenance.....	14
Repairs.....	15
Table of problems	16
Maintenance and servicing	17
Maintenance and servicing	17
Waste disposal	17
User training	17
Wiring diagrams	18
E-Drive optima wiring diagram.....	18
E-Drive optima Dual wiring diagram	18
E-Drive optima Twin wiring diagram.....	20
Technical characteristics	21
Plans	22
Drive unit.....	22
.....	22
Control handle.....	22
Assist grip	23
Battery holder	23
Description of the drive unit	24
Indicative table of braking distances	25

FOREWORD

This documentation ensures the correct installation and use of the motorised unit E-Drive optima.

Each person must have read and understood the contents of this documentation. Following the instructions in this documentation will avoid hazards, increase reliability and extend the life of the equipment. In addition to these instructions, it is imperative that the legal provisions and other regulations applicable at the place of installation or use are also observed, such as:

- Accident prevention regulations.
- Workplace safety and compliance regulations.

This documentation is an integral part of E-Drive optima:

- Always keep these operating instructions at the place where E-Drive optima is used.
- Make sure that the instructions for use are available to the user at all times.
- If you sell or pass on E-Drive optima to a third party, always hand over these operating instructions.

Supporting documents

Other supporting documents must be taken into consideration (battery + battery charger). These other documents are considered an integral part of this documentation. Please keep all documents at all times. If you sell the E-Drive optima set or pass it on to a third party, make sure to always hand over all documents as well.

Markers in the text

Certain points in these instructions are indicated by special symbols. These symbols allow you to differentiate between the following:

"Normal text": explanatory / descriptive

- : Lists
 - : Operations to be carried out
- Information: Specific additional information.

Copyright

These assembly instructions contain copyright information. Any copying, printing, image retrieval, as well as reproduction, processing, duplication or distribution by any means of these assembly instructions, in whole or in part and in any form whatsoever, is prohibited without the prior written permission of TENTE SAS.

© 2021 TENTE SAS

All rights reserved.

Manufacturer's address

For further information, please contact the manufacturer:

TENTE SAS

11 rue de l'Orme Brisé

ZI Pringy

77986 St Fargeau Ponthierry

Telephone: +33 (1) 60 65 23 00

Fax: +33 (1) 60 65 23 41

Email: info.fr@tente.com

Website: www.tente.com

Documentation Officer

Bernard LAURENT

TENTE SAS

11 rue de l'Orme Brisé

ZI Pringy

77986 St Fargeau Ponthierry

Motor pictogram



The pictogram on the motor warns of the risk of hands being crushed.

Take this into account when handling with or working on the motor.

SAFETY

Use as intended

E-Drive optima is only intended for indoor use on vehicles that are to be moved by hand. It should only be used with TENTE battery packs or battery packs with identical characteristics. Connection to other electrical sources is forbidden without prior agreement from TENTE SAS.

The intended use also includes compliance with all the information in these operating instructions, in particular the safety instructions and technical data.

Any other use of the device is considered to be non-compliant.

In particular, the following uses are non-compliant:

- Use in areas with a risk of explosion.
- Household use.
- Outdoor use.
- Use with electrical sources other than TENTE battery packs.
- Use of E-Drive optima after conversion without the permission of TENTE SAS.
- Assembly, connection and/or use by insufficiently qualified personnel.
- Use by unauthorised persons.

TENTE SAS accepts no liability for damage resulting from improper use. If E-Drive optima is used improperly, the liability of TENTE SAS for defected material will be extinguished and the warranty will be void.

Note on residual risks

E-Drive optima has been developed according to the latest technical knowledge, safety regulations and applicable standards. Sources of danger have been eliminated as far as possible from the design stage or secured by appropriate devices. However, there may be residual risks in using the control system. Dangers to persons or damage to E-Drive optima and other material damage may occur in particular if E-Drive optima:

- Is incorrectly installed, connected and put into operation by untrained personnel;
- Is used in a way that does not conform to its intended use.

Qualification of assembly personnel

Assembly personnel must have read and understood these instructions. They should also have specific knowledge in the following areas:

- Assembling electrical equipment;
- Drilling and screw connections.

Qualification of connection personnel

Connection personnel must have read and understood these instructions. They should also have specific knowledge in the following areas:

- Making and checking electrical connections;
- Professional electrical wiring.

Qualification of operating personnel

Users of the control system must have read and understood these instructions. They should also have specific knowledge in the following area:

- Using manually moved trolleys such as trolleys, spider bases, food distribution trolleys, etc.

Personal protective equipment

Make sure that all work is carried out in protective clothing appropriate to the activity in question. Protective clothing should be chosen according to the risks involved in the. In particular, protective clothing must protect against the following risks:

- Body injuries;
- Hand injuries;
- Foot injuries.

Basic safety instructions

Avoiding the danger of serious injury

Risk of electric shock due to incorrect connection of E-Drive optima.

- Make sure that all connections are made by qualified personnel.
- Make sure that all wiring is done according to the rules of the trade.
- Make sure that the connecting cables are not damaged.
- Only connect E-Drive optima with the link cables supplied with the device.
- For the E-Drive optima power supply, only use the battery packs supplied by TENTE or models with identical characteristics.

Markers associated with hazard notes



DANGER

Notes with the word DANGER indicate a dangerous situation that could result in death or serious injuries.



WARNING

Notes with the word WARNING indicate a dangerous situation that may result in serious injuries.



CAUTION

Notes with the word CAUTION indicate a situation that could result in minor or moderate injuries.

Markers associated with equipment damage notes

ATTENTION! These notes indicate a situation that could result in a risk of equipment damage.

TRANSPORT

- Transport the E-Drive optima components in their original packaging.
- If you no longer have the original packaging, pack each E-Drive optima component to protect it from moisture and mechanical damage.

Avoid the risk of serious injury.

Risk of injury when moving by catching body parts.

- Wear close-fitting work clothes during use. Do not wear any dangling jewellery. Protect long hair with a hair net.

Avoid the risk of minor injuries.

Risk of bruising due to collision with other people.

- During use, ensure that no one is within the travel range of the trolley.
- **Maintain control of the vehicle until stops completely.**

Equipment damage due to loose control system cables.

- Ensure that all connecting cables have been properly secured and connected.

Malfunction due to poorly inserted connectors.

- Make sure that all connectors are properly fitted into their sockets.

Malfunction due to improperly attached components.

- Make sure that the mounting screws of each component are tight. Make sure that the screw heads do not interfere with normal operation.

Equipment damage and malfunctions when used outdoors.

Dirt and moisture can impair operation and cause damage to the E-Drive optima system.

- Only use detergents that are not aggressive to plastics and metals.

DESCRIPTION

Description of use

The E-Drive optima motorised wheel can be fitted, under certain spatial conditions, to vehicles in order to assist the users of this equipment when moving and manoeuvring.

It allows equipment to move effortlessly with a starting force of up to 25 DaN (50 DaN for the optima twin version).

Components of the E-Drive optima set

The E-Drive optima set consists of the following components:

- **One control handle and one assist grip:**



The control handle (details page 24) is used to operate the E-Drive optima drive unit. It is connected to the drive unit.

- **A drive unit:**



It is equipped with an electric geared motor (plan page 26, description page 28) which ensures the rotation of the drive wheel + 1 electric motor allowing the drive wheel to be raised or lowered.

The drive unit has 2 handle connectors, allowing 1 set of handles to be mounted on each side of the vehicle (optima dual version) or to be connected to a second motor (optima twin version).

NB: The second connector can also be used to connect to a computer for configuration. **(Configuration performed by TENTE qualified personnel only).**

- **A 24 volt 11.6A lithium-ion battery:**



It is protected by 1 x 5A input fuse and a 20A output fuse (Gs type).

- **A 220/240V 2A fuse-protected battery charger:**



- **A battery holder to be fixed to the vehicle (plan page 23):**



- **Electrical cables for connections.**

Optional accessories

- Clamps for mounting the brackets on round tube:
 - For tube diameters from 27 to 31mm.
 - For tube diameters from 31 to 35mm.
 - Wedges for mounting on a flat surface.
- Additional set of handles (optima dual).
- Link cable to pair 2 E-Drive optima sets to double the power (Optima Twin).
- Spare wheel + accessories for replacement.
- Additional battery.

ASSEMBLY

Cautionary note

The assembly depends on the trolley on which the E-Drive optima components are installed.

The following assembly explanations may change depending on the brackets used.

The assembly must be carried out in compliance with safety standards.

We recommend grounding the application to avoid electrostatic risks.

ATTENTION! Incorrect assembly may damage the control system.

- Ensure that the control system is assembled by qualified professional personnel.

ATTENTION Incorrect assembly position may damage a component.

- For each component, choose an assembly position where it will not be damaged during movement.

Nameplate

The nameplate is located on the drive unit.

This nameplate gives the following information:

- Manufacturer's address
- Serial number
- Supply voltage
- Protection class (IPX4)

ASSEMBLY OF THE CONTROL HANDLE AND THE ASSIST GRIP

The control handle and the assist grip are designed for assembly on flat surfaces or on tubes. These two assembly options are explained below using the control handle as an example.

Assembly on a flat surface

The following tools and equipment are required to assemble the control handle on a flat surface:

- Drill
- 6 mm drill bit
- 4 screws
- 2 mounting wedges
- Open-ended spanner
- Threaded nuts

TENTE SAS offers optional mounting wedges.

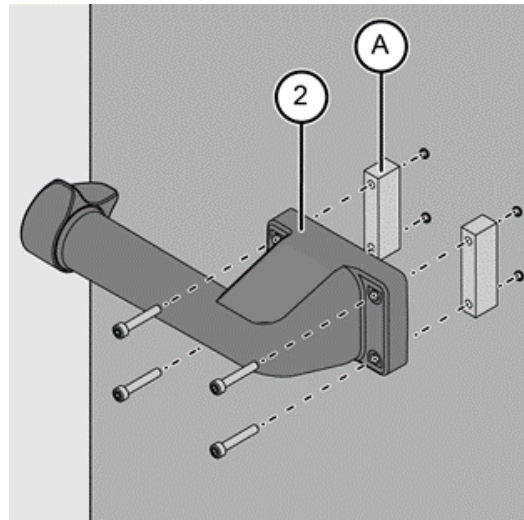

To assemble the control handle on a flat surface, proceed as follows:

➤ Drill the required holes.

The exact dimensions are shown in the illustration on page 22.

➤ Insert the mounting wedges (A) into the control handle (2).

➤ Secure the control handle with the screws.

➤ Be careful not to pinch or damage the control cable.

➤ Check that the control handle is secure.

Assembly on a tube

To assemble the control handle on a tube, you need the following tools and equipment:

- Open-ended spanner
- 2 mounting wedges (A)
- 2 mounting brackets (B)
- 4 screws

Optional tube mounting kits are available from TENTE SAS.

The mounting kits include brackets and wedges for tubes with diameters ranging from 27mm to 31mm or 31mm to 35mm.

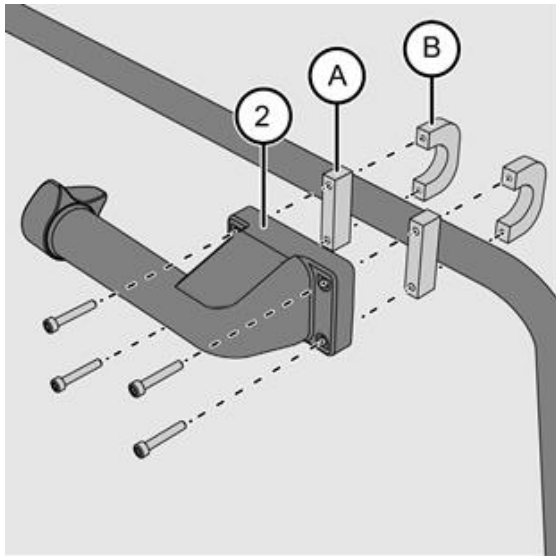

To assemble the control handle on a tube, proceed as follows:

- Insert the mounting wedges (A) into the control handle (2).
- Place the handle on the tube.
- Screw on the control handle with the mounting brackets (B).
- Make sure that the control handle is secure.

Assembly of the drive unit.

Adapt the bracket for assembly of the drive unit. The trolley for E-Drive optima must meet the following requirements:

- The castors of the trolley must be suitable for the weight to be moved.
If you have any questions about this, please contact your distributor or TENTE SAS.
- The trolley must be equipped with one (or 2) mounting plate(s) with M8 threaded holes or 9mm diameter smooth holes.
- The mounting plate(s) must be designed in such a way that the drive forces generated when operational can be transmitted. The design should also be taken into account when it comes to the vertical thrust force of the drive unit. For help with the design, please contact your distributor or TENTE SAS.

- The ideal distance between the floor and the mounting plate(s) is 170mm to 180mm.
- The mounting plate(s) must be assembled so that the main direction of travel of the device is in line with that of the vehicle.

To secure the drive unit, each mounting plate must have three 9 mm diameter mounting holes, or three M8 threaded holes. The screwing depth must be at least 10 mm. The arrangement of the fixing holes depends on the desired main direction of movement (see arrow in the image below).

Direction of travel

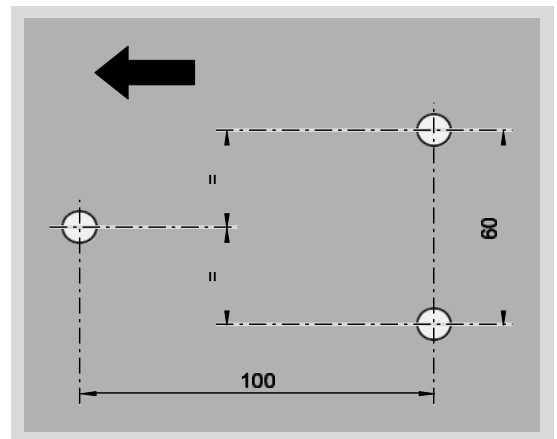

Recommended positions of the mounting plate (optima or optima dual version)

The position of the mounting plate varies depending on the intended use and the type of castors.

If the vehicle has fixed castors, the mounting plate must be positioned so that the drive wheel is located between the fixed castors.

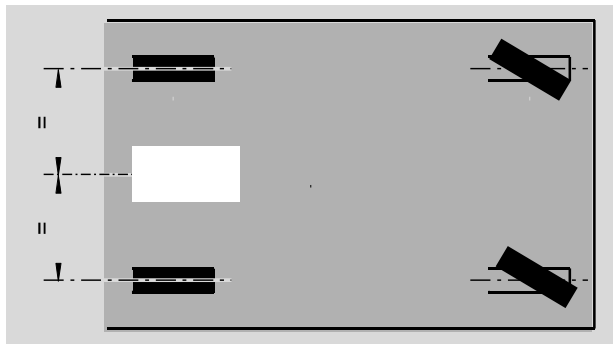

If the vehicle only has swivel castors, the mounting plate must be positioned so that the drive wheel is closest to the centre of the frame.

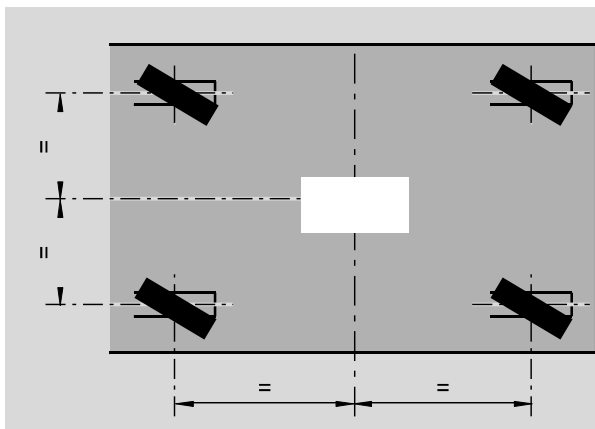

➤ If you have any questions about the position of the mounting plate, please contact your dealer or TENTE SAS.

Recommended positions of the mounting plates (optima twin version)

The position of the mounting plates varies depending on the intended use and the type of castors.

If the vehicle has fixed castors, the mounting plates must be positioned so that the drive wheels are located between the fixed castors.



If the vehicle only has swivel castors, the mounting plates must be positioned so that the 2 drive wheels are closest to the centre of the frame.

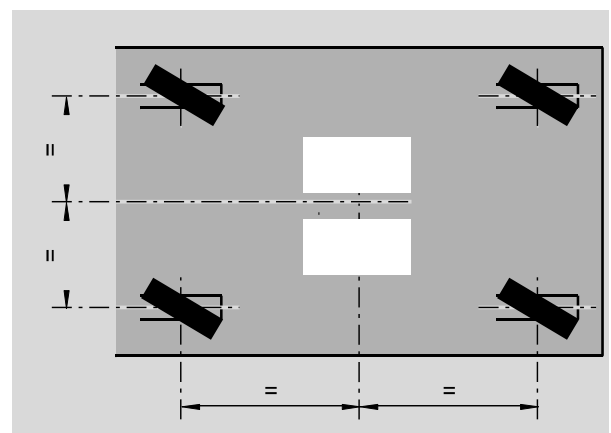

➤ If you have any questions about the position of the mounting plate, please contact your dealer or TENTE SAS.

Unpacking the device(s)

CAUTION

Danger of cuts from sharp edges of the device.

- Protective gloves must be worn when handling the device.
- Remove the device from its packaging.
- Check the device for transport damage.
- If you detect any damage during transport, please contact your distributor or TENTE SAS.

MOUNTING AND CONNECTING THE UNIT

Equipment needed

The drive unit is delivered in the extended position (drive wheel in the lowered position) so that the mounting screws can be tightened.

To assemble the drive unit on the prepared frame, you need:

- The drive unit
- Torque wrench with setting range up to 20 Nm
- Three M8 screws, minimum grade 8.8 (DIN EN 24017). The choice of screw length should be made according to the type of mounting (threaded holes or plain holes + nuts).
- Appropriate tools depending on the type of mounting

Mounting the drive unit

To mount the unit on the frame, proceed as follows:

- Lightly screw the two M8 screws (2) into the threaded holes in the mounting plate.
- Or
- Lightly screw the two M8 screws (2) with the corresponding nuts onto the mounting plate.
 - Slide the 2 fixing screws into the holes (3) of the mounting plate.
 - Insert the third screw through the hole (1) in the mounting plate and attach it to the mounting plate.
 - Tighten the three screws by applying a torque of 20 Nm.

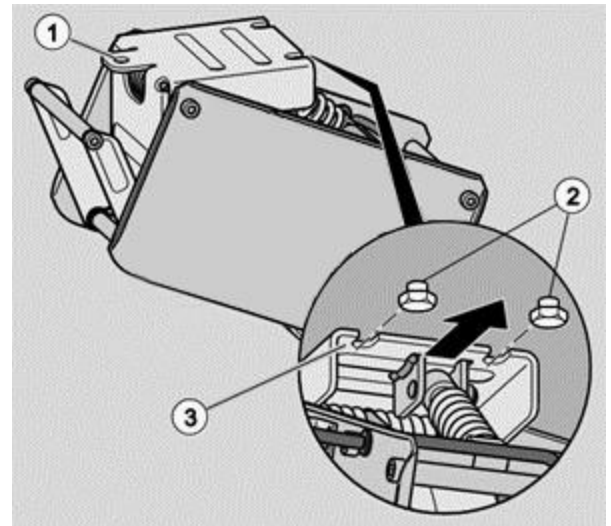

Connecting the drive unit



DANGER

Danger of electric shock if the device is incorrectly connected.

- The device must be connected according to one of the electrical connection diagrams on pages 18 to 20.



DANGER

When connecting the electrical cables and then starting, make sure that no hand or object is placed between the mounting plate and the moving part of the wheel. There is a risk of severe pinching and cutting.

ATTENTION!

Malfunctions or material damage to the appliance due to incorrect connections.

- Make sure that the connections are made correctly.

Optima version: 1 handle + 1 motor

See diagram on page 18

Connect the handle to one of the 2 connectors on the motor:

Push the connector in until it clicks into place. Please take your time to check the first alignment of the two parts by using the markings on the male and female parts.

- Make sure that the connectors fit properly.
- Secure cables and connectors with appropriate devices to prevent them from being pulled out or damaged otherwise.
- Make sure that the cables cannot be damaged when moving the vehicle.

Connect the drive unit to the battery:

Push the battery connector into the connection socket on the device until it clicks into place.

- Make sure the connectors fit properly.

Optima dual version: 2 sets of handles + 1 motor

See connection diagram on page 19

Connect each handle to each connector on the motor (remember: 2nd handle and 2nd cable supplied as an option):

Please take your time to check the first alignment of the two parts by using the markings on the male and female parts.

- Make sure that the connectors fit properly.
- Secure cables and connectors with appropriate devices to prevent them from being pulled out or damaged otherwise.
- Make sure that the cables cannot be damaged when moving the vehicle.

Connect the drive unit to the battery:

Push the battery connector into the connection socket on the device until it clicks into place.

- Make sure that the connectors fit properly.

Optima twin version: 1 handle + 1 cable between the motors + 2 batteries + 2 motors

See connection diagram on page 20

Connect the handle to a connector on a motor. Connect the second motor using the link cable:

Please take your time to check the first alignment of the two parts by using the markings on the male and female parts.

- Make sure that the connectors fit properly.
- Secure cables and connectors with appropriate devices to prevent them from being pulled out or otherwise damaged.
- Make sure that the cables cannot be damaged when moving the vehicle.

Connect each drive unit to its battery:

Push the connector of each battery into the connection socket on each unit until it clicks into place.

- Check that the connectors fit properly.

The motor connected to the handle is the master. The one connected by the link cable reproduces the actions of the master motor.

Cautionary note

Risk of damage to the control system due to incorrect electrical installation.

- Make sure that the control system is assembled by qualified professional personnel.
- Make sure that the cables and connectors cannot be pulled out or damaged.
- Make sure that all components are properly assembled.
- Secure cables and connectors with appropriate devices to prevent them from being pulled out or damaged.
- Make sure that the cables cannot be damaged when moving the vehicle.

OPERATION

General information

E-Drive optima is an electrically powered assistance for moving vehicles. It allows materials to be moved effortlessly with a force of up to 25DaN (or 50DaN for the Optima twin version).



The user must remain in control of the trolley while it is moving.

A drive wheel disengagement (lift) function allows the vehicle to be pulled by a motorised vehicle at speeds up to 16km/h (4.4m/s). In normal operation, the maximum speed can be set from 1km/h to 6km/h. Forward and backward speeds can be set individually.

Safety features

E-Drive optima is equipped with the following safety features:

- Stop button on the handle (red).
- Power failure on the battery.
- The braking of the drive unit is activated as soon as the potentiometer returns to the neutral position or by pressing the red button.
- If the vehicle is moved without action on the potentiometer and the wheel is in the lowered position, beyond a speed equal to the maximum programmed speed + 1km/h or after 11 seconds in case of towing at a speed between 2km/h and the set speed + 0.9km/h, the wheel is raised automatically.
- In the optima dual version, the simultaneous use of both control handles causes the system to stop. To restart, apply the start-up procedure.

Start-up and operation after ensuring that all components of E-Drive optima are correctly connected and after setting the operating parameters:

- Make sure the battery is charged.
- Turn the battery key to the "ON" position. E-Drive optima is ready to go.
- Grab the 2 handles.
- Press the green (on) button. The green

LED flashes slowly.

- Using your thumb, gently press the potentiometer in the desired direction. Activating the potentiometer will automatically lower the wheel to the ground (time required = approx. 1 second) and then start in the desired direction. The green LED light on the handle stays on continuously indicating that the wheel is in contact with the ground.

Default maximum speed = 4km/h forward (modifiable from 1 to 6km/h) and 3km/h reverse (modifiable from 1 to 6km/h).

The more intensively the potentiometer is pressed, the higher the speed. This feature allows the equipment to be controlled with great precision during delicate manoeuvres.

- To slow down the trolley, set the potentiometer to the neutral position, or press the red button (stop). The speed will decrease to 0.3km/h and then stop.

E-Drive optima can help to slow down when going downhill. To do this, leave the potentiometer in the neutral position. The motor brake will assist the user. The potentiometer should not be operated in the opposite direction. This could cause premature wear of the wheel.



When descending a ramp and stopping before reaching the bottom, activate the potentiometer and release it before restarting.

This helps to maintain the motor brake function and to avoid any risk of the wheel disengaging after restarting.

- Once the wheel is in the lowered position, the wheel remains in this position during use. When not in use, by default, the wheel is raised after 600 seconds (changeable from 10 to 999 seconds).
- To stop the system, press the red (stop) button on the handle (braking and then retracting the wheel) and then cut the power to the battery.



To preserve battery life, the system has an automatic shutdown.
Default after 10 minutes without use (changeable from 10 seconds to 999 seconds). However, it is recommended that the system is turned off after each use.

BATTERY AND BRAKE WARNING INFORMATION

Battery alert information

Low battery alert

When the battery reaches a low charge level, the LED on the handle flashes rapidly. The system must be shut down and the battery replaced or recharged.

If the battery is not replaced or recharged, there are two possible cases:

- 1) Wheel up: The wheel will not come down
- 2) Wheel down: The wheel will automatically go up and the system will stop.

In both cases mentioned above, replacing the empty battery with a charged battery will allow a return to normal operation.



The charge level on the battery can be checked by pressing the control button on the battery (key in "ON" position).



When the battery is discharged, do not attempt to turn it on again after it has been switched off. Replace it with a charged battery and charge it using the charger provided by TENTE.



Do not use the battery while it is charging. To recharge it, remove it from its holder and connect it to the charger provided by TENTE.

Braking information



Stopping distance

It varies according to:

- The weight of the vehicle
- The nature of the floor (concrete, tiles, linoleum, parquet, etc.)
- The quality of the supporting castors

➤ An indicative table of braking distances is available on page 25.



Park brake:

E-Drive optima does not have a parking brake. The motor brake is activated as soon as the potentiometer returns to the neutral position or by pressing the red button.

If the equipment needs to be parked for a long period of time, activate the brake on the castors or any other device to immobilise the equipment.



The E-Drive optima castor is not designed to stop a trolley on a slope.

Cleaning and maintenance

In order to guarantee a safe and long-lasting operation, it is necessary to regularly check the general condition and to carry out any cleaning or maintenance operations on E-Drive optima.

- Remove any wires that may be trapped in the wheel hub.
- Remove external dirt with a dry cloth or a cloth moistened with slightly soapy water.
- Make sure that no liquids can enter the components of E-Drive optima when cleaning it.
- Grease the cam for the wheel lift every 6 months.
- **In case of wheel tread wear > 5mm on the spoke, replace the wheel with the optional repair kit provided by TENTE.**



Incorrect cleaning may cause irreparable damage to the control system.



Avoid impacts with objects or obstacles when moving the equipment (when the motor is active or when towing).

Impacts can damage electronic components and cause serious breakdowns requiring the replacement of parts (bonnet, electronic board, motor, etc.)

Repairs

If the system fails, follow the following steps immediately: Switch off the power supply by turning the battery key to the "OFF" position.

- Make sure that there is no external cause for the breakdown (wires stuck in the wheel, cut or disconnected electric cable, etc.).
- In case of a simple breakdown (disconnected cable, trapped wires), the problem should be corrected by qualified personnel.
- For any other breakdown, contact the TENTE SAS after-sales service who will tell you what to do.
- Only switch the control system on again once the fault has been rectified.

If after the repair, the drive wheel is in the lowered position, proceed as follows:

- Turn the battery key to the "ON" position.
- Press the red button on the control handle:
 - The wheel is raised and E-Drive optima is ready to work again.



If the wheel fails to lift automatically, dismantle the motor and send it off for repair works.

Table of problems

Problems	Causes	Solutions
E-Drive optima will not lower itself.	A cable, connector or limit switch is defective.	<ul style="list-style-type: none"> ➤ Check the cables and connectors.
The control system is switched off while the E-Drive control unit is in the lowered position.	The power supply was interrupted while the unit was on.	<ul style="list-style-type: none"> ➤ Check if the power supply is good (battery charged, in the ON position and correctly connected). ➤ If necessary, replace the battery or reconnect the cables correctly. ➤ Press the green button on the control handle. ➤ Operate the potentiometer.
The control system cannot be switched on, the battery cannot be charged.	The battery fuse is defective.	<ul style="list-style-type: none"> ➤ Have the fuse checked by a qualified electrician. ➤ Replace defective components.
The control system cannot be switched on, the battery cannot be charged.	The battery is defective.	<ul style="list-style-type: none"> ➤ Have the battery checked by a qualified electrician.
The drive unit will not start.	The wiring is defective.	<ul style="list-style-type: none"> ➤ Have the wiring checked by a qualified electrician. ➤ Replace defective components.
The drive unit will not start.	The traction motor or gear motor of the E-Drive optima drive unit is defective.	<ul style="list-style-type: none"> ➤ Contact TENTE SAS.
The drive unit will not start.	The control system is defective.	<ul style="list-style-type: none"> ➤ Contact TENTE SAS.
The drive unit is continuously lowering and lifting itself.	The microswitch is defective or incorrectly positioned.	<ul style="list-style-type: none"> ➤ Reposition the microswitch to the upper position ➤ Contact TENTE SAS.
The drive unit will not stay in the lowered position.	The wiring is defective.	<ul style="list-style-type: none"> ➤ Have the wiring checked by a qualified electrician.
The drive unit will not stay in the lowered position.	The drive system E-Drive optima has a mechanical fault.	<ul style="list-style-type: none"> ➤ Contact TENTE SAS.

MAINTENANCE AND SERVICE

Maintenance and service

ATTENTION! The use of non-original spare parts may cause irreparable damage to E-Drive optima and will void the warranty.

- Do only use original spare parts from TENTE.

ATTENTION! Improper repair work may cause irreparable damage to E-Drive optima.

- Apart from replacing the wheel, do not carry out any repair work on E-Drive optima components.

Replace defective components in their entirety.

Apart from the lubrication and wheel replacement mentioned on page 15, E-Drive optima components are maintenance-free. Do not open the motor protection box and/or the gear motor.

- Make sure that all defective components are replaced with original spare parts from TENTE.
- Always have defective components replaced by qualified professional personnel.

Waste disposal

The environmentally sound disposal of electronic modules, recyclable materials and other components is regulated by national and regional legislation. Disposing of them in household waste is prohibited. For more detailed information on waste disposal, please contact your local waste disposal authority. Environmentally friendly disposal involves sorting the parts. Sort the parts as follows:

- Hazardous waste
 - Electrical and electronic waste
 - Metals
 - Plastics
- Please dispose of the batteries via the hazardous waste collection.
 - Dispose of the remaining parts according to their recyclability.



USER TRAINING

To enable users to familiarise themselves with E-Drive optima, TENTE offers user training at their premises.

This training is carried out free of charge over half a day by qualified TENTE personnel. The training takes place after the installation of E-Drive optima on the vehicle.

Points discussed:

- Start-up
- Use
- Battery replacement + charging

NB: During this training, the trainer will be able to configure the operating parameters according to the users' wishes.

Only TENTE staff are authorised to change the settings.

If this rule is not observed, the warranty will be void and TENTE will not be liable for any problems.

WIRING DIAGRAMS

E-Drive optima wiring diagram

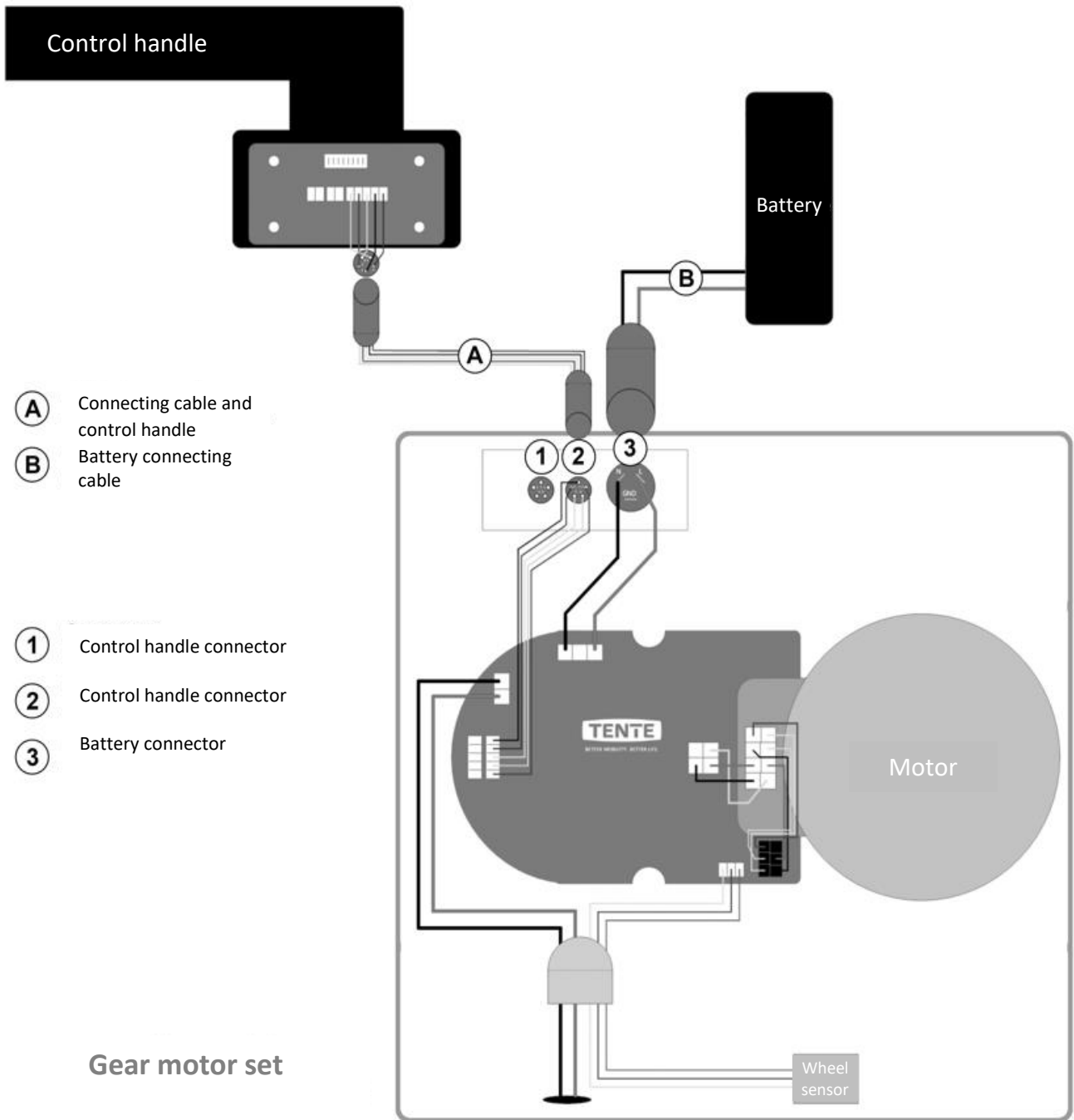

E-Drive optima dual wiring diagram

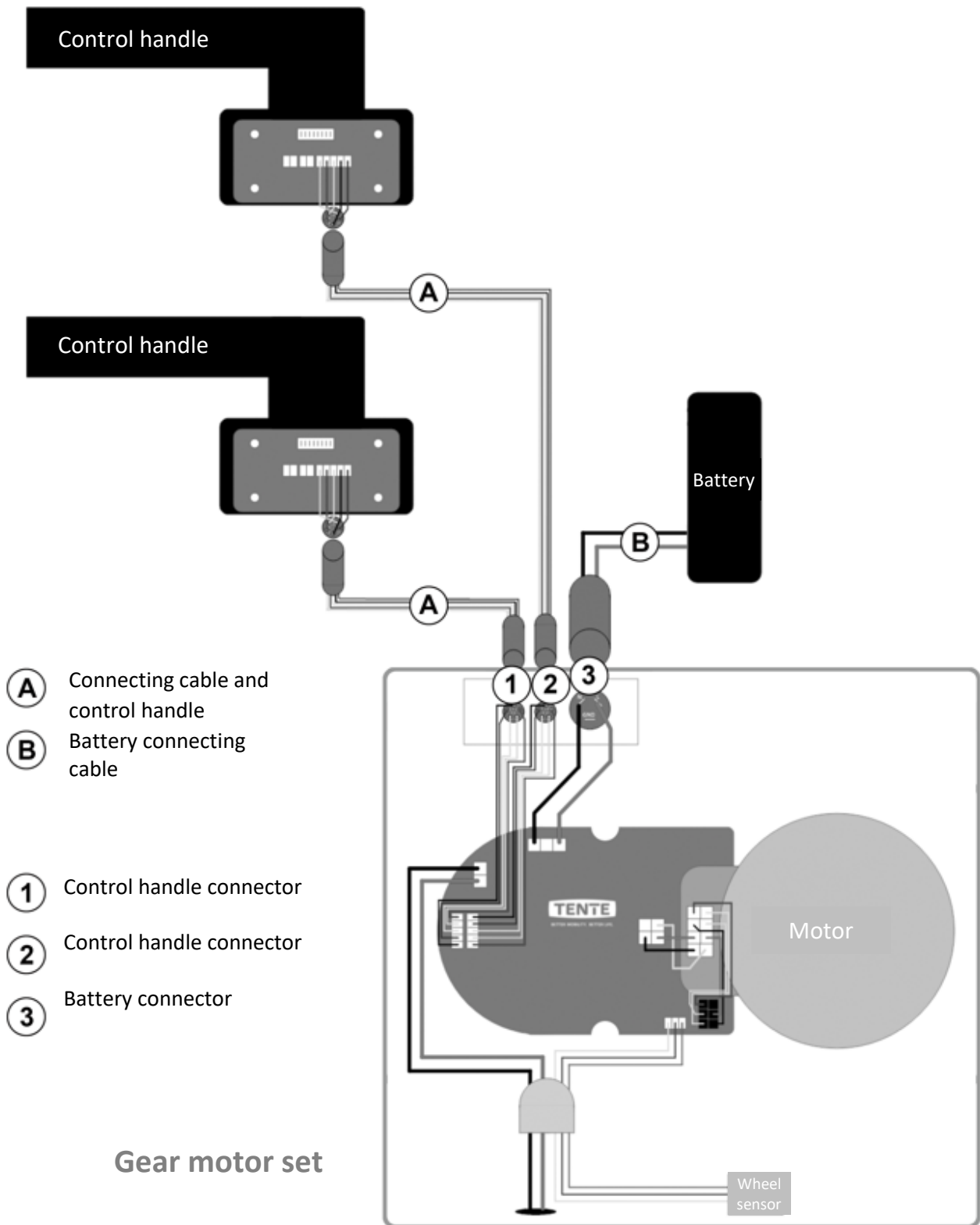

E-Drive optima twin wiring diagram

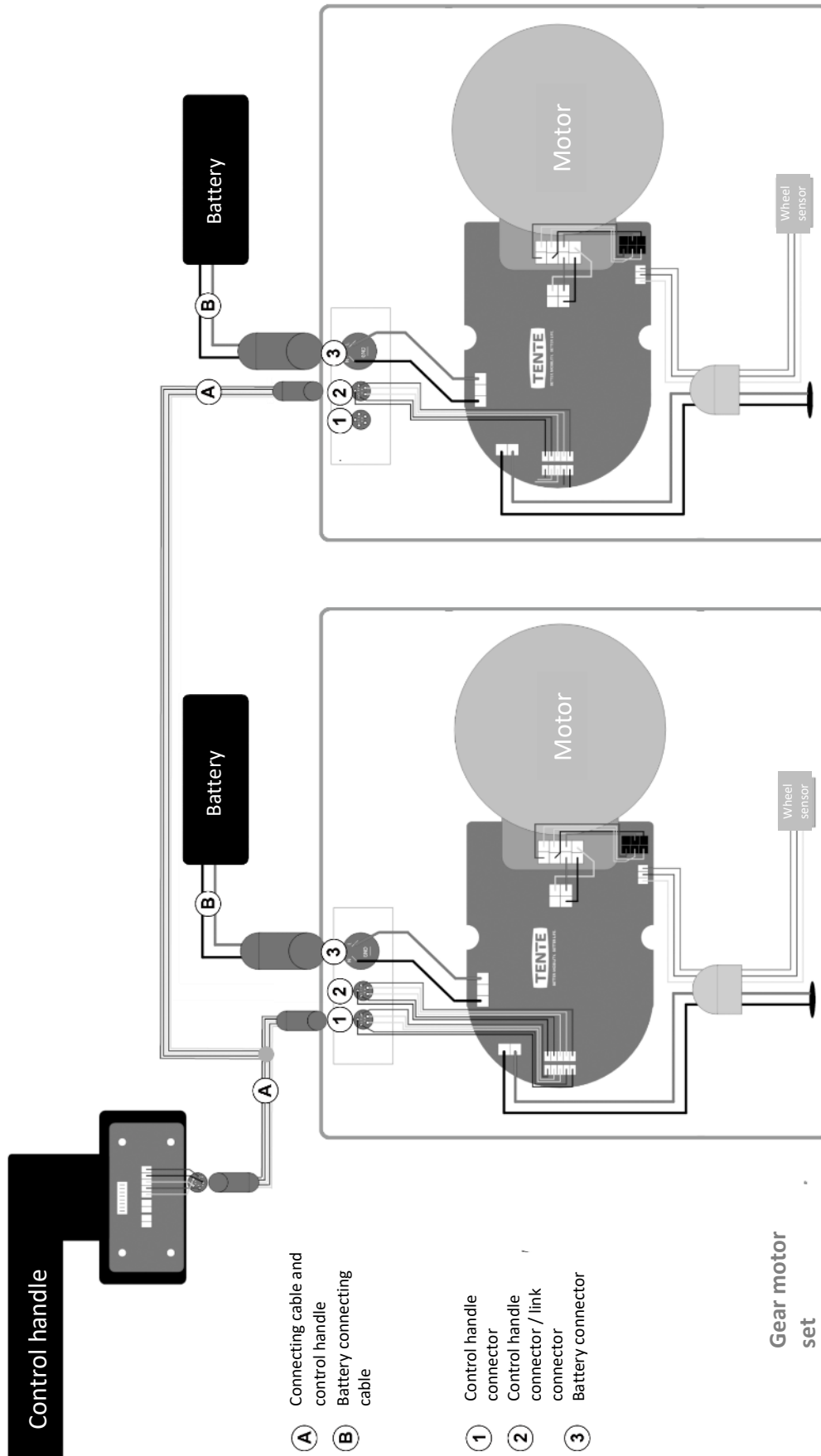

TECHNICAL CHARACTERISTICS

Drive unit with gear motor

Supply voltage	24 V DC
Power consumption in standby mode	0.5mA (wheel up) 14mA (wheel down)
Power consumption in operation	15A max
Storage temperature	From -10 to +40 °C
Permitted ambient conditions during operation	From 0 to +40 °C Air humidity 90%, non-condensing
Protection class	IPX4 (water spray from all sides)
Weight	7.25 Kg

Control handle

Supply voltage	24 V DC
Power consumption in standby mode	28mA
Power consumption in operation	33mA
Storage temperature	From -10 to +40 °C
Permitted ambient conditions during operation	From 0 to +40 °C Air humidity 90%, non-condensing
Protection class	IPX4 (water spray from all sides)

PLANS

All dimensions are in mm

Drive unit

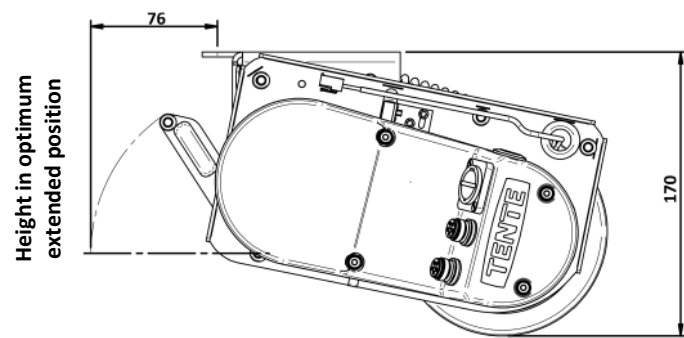
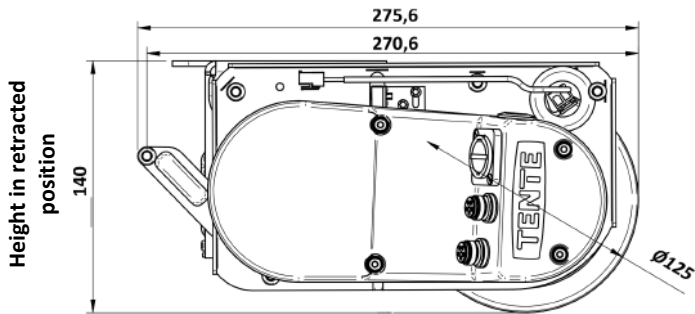

276 / 322 (unlocked handle)

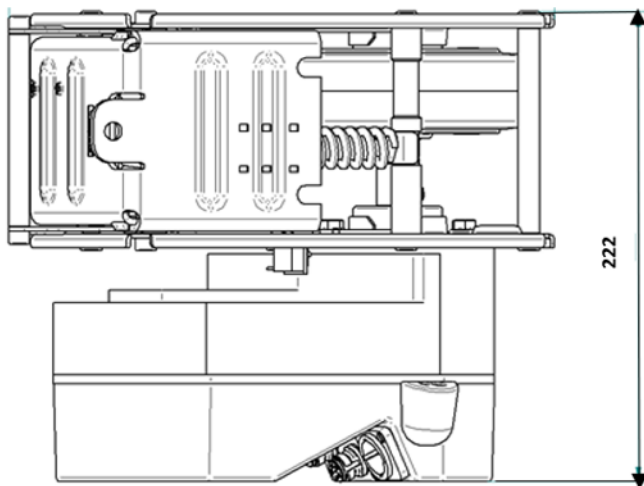

Control handle

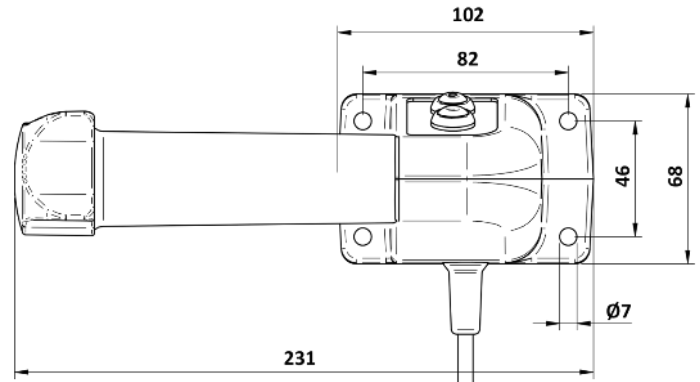

- ① ON
- ② STOP
- ③ OPERATION LIGHT / BATTERY CHARGE WARNING



The green button indicator is off. E-Drive optima is not activated.

- ① ON
- ② STOP
- ③ OPERATION LIGHT / BATTERY CHARGE WARNING



The green button indicator has **3 states**:

1. **Slow flashing:** System is running, E-Drive optima is in the up position (disengaged).
2. **Solid:** system is running, E-Drive optima is in the lowered position (ready to start or in traction)
3. **Fast flashing:** system is running, E-Drive optima is in the lowered position, battery level is low (replace or recharge battery).

The red button is the assisted stop button. When pressed, E-Drive optima decelerates to a stop and then rises again.

Assist grip

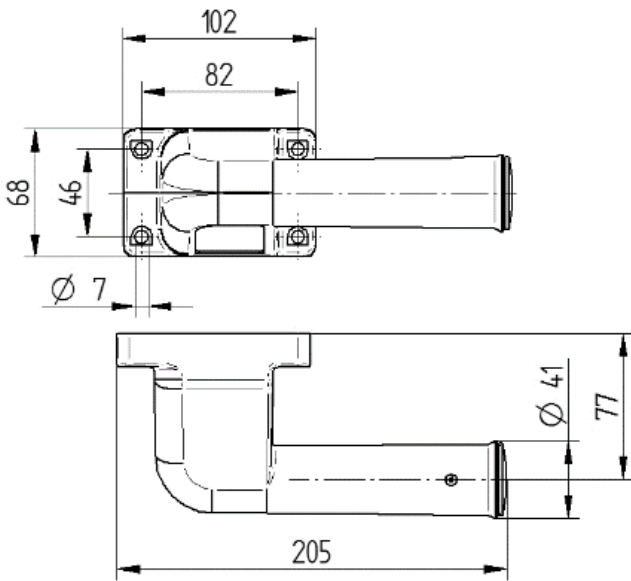

Battery holder

The battery holder is equipped with a slide for the battery, which automatically connects to the motor's power cable. The holder is fixed to a flat surface by means of 4 or 6 M5 screws.

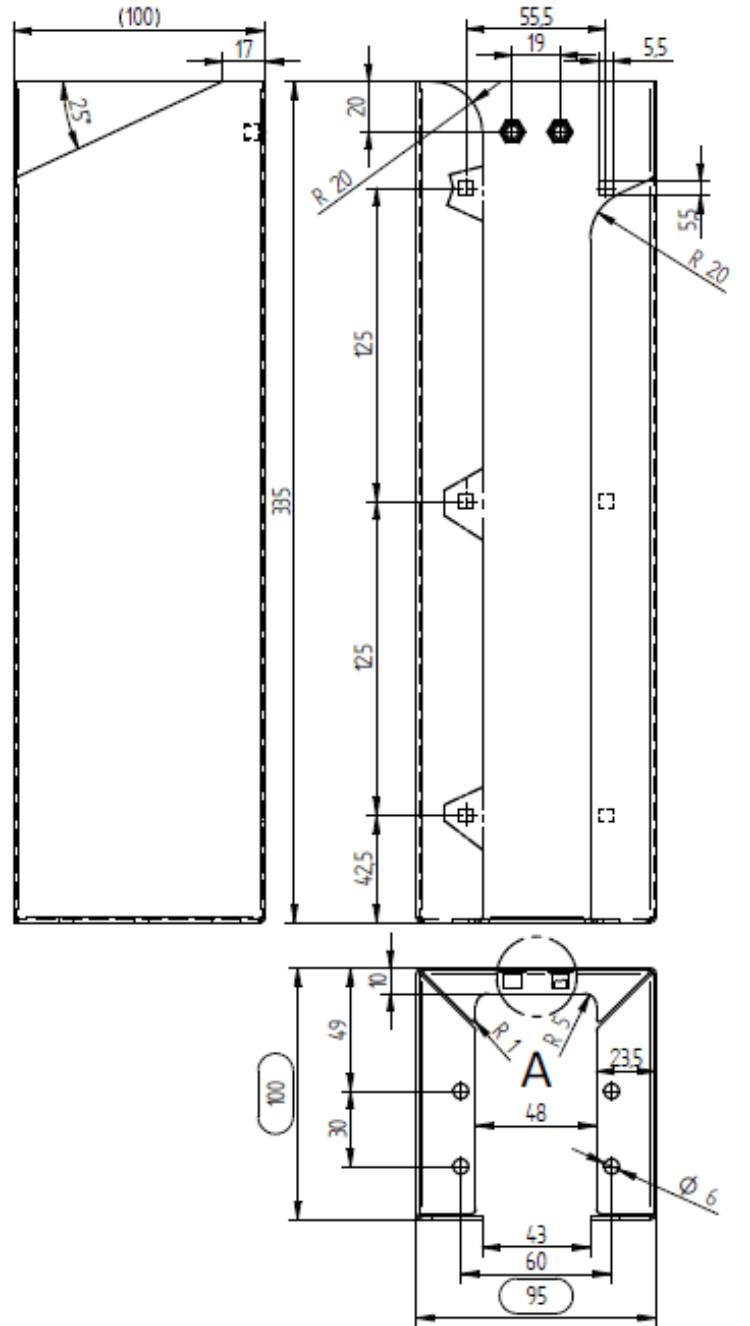

DESCRIPTION OF THE DRIVE UNIT

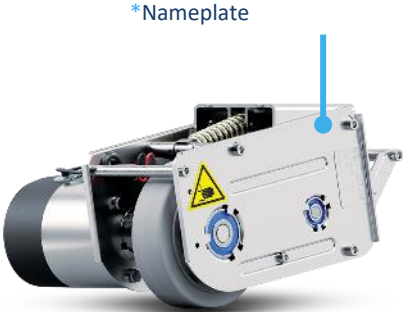
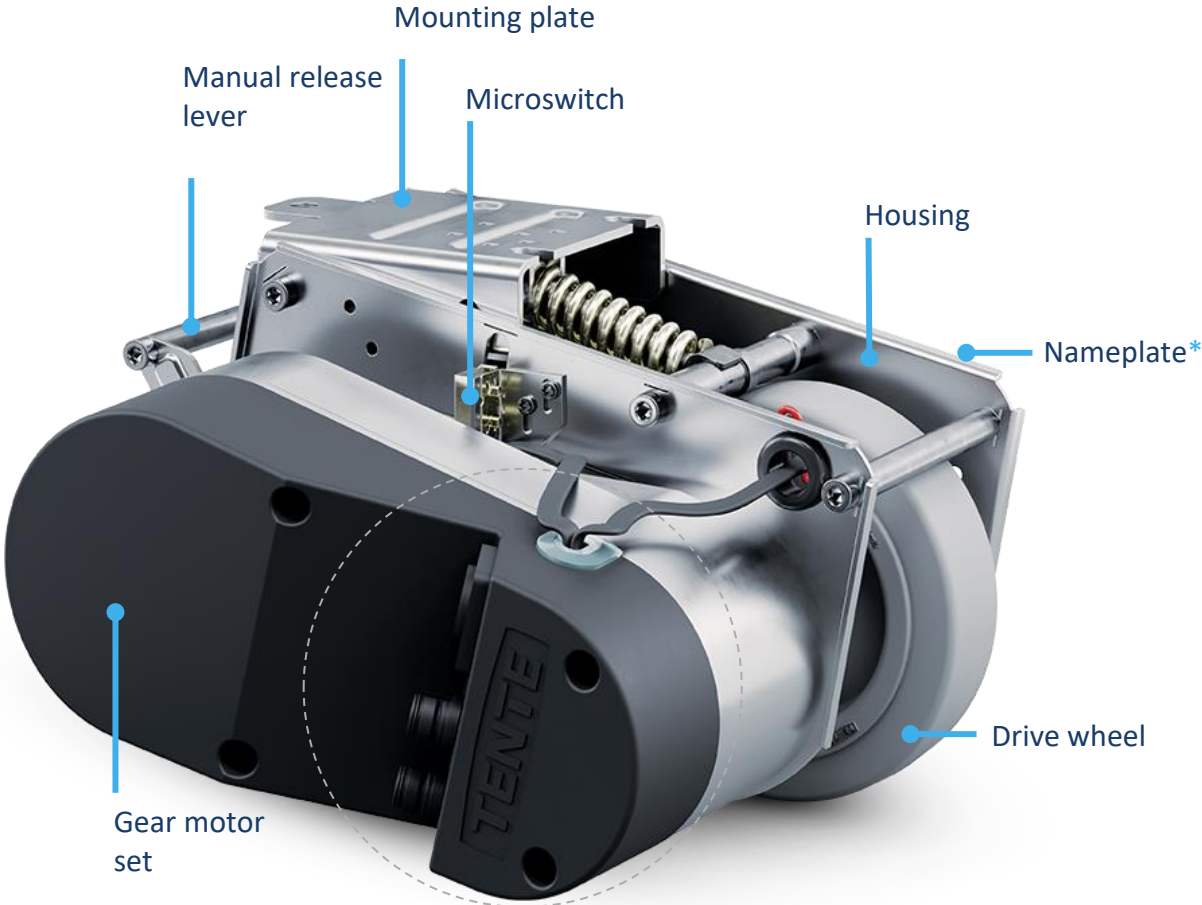

INDICATIVE TABLE OF BRAKING DISTANCES

Braking distances depend on several parameters:

- The nature of the floor (concrete, tiles, wood, plastic, etc.)
- The condition of the floor (smooth, grainy, dry, wet, etc.)
- The slope
- Travel speed
- The gross load moved
- The quality and number of wheels and castors

The values shown in the table below reflect measurements made under the following conditions:

- Floor type: tiles
- Floor condition: smooth, dry and clean
- Flat floor
- Speed: see table
- Load moved: see table
- 4 swivel castors, diameter 160mm.
- Aluminium wheels with ball bearings and cast polyurethane tread (Novatech TENTE) with a Shore hardness of 92A.
- Distance travelled between the stop of the potentiometer and the complete stop without the user holding it back.

E-Drive optima motorised wheel	200 kg	300 kg	500 kg
Speed 3km/h	0.90m	1.00m	1.50m
Speed 4km/h	1.20m	1.50m	2.10m



These values are indicative and not contractual. Each user may, under their own responsibility, carry out similar measurements on their own equipment and at the place of use.



www.tente.com