

# E-Drive ultimate control system Operating instructions

06/2021

Translation of the original German operating instructions

# Contents

<b>Foreword</b> .....	<b>4</b>
Availability .....	4
Other applicable documents .....	4
Structural features in the text .....	4
Figures .....	4
Copyright .....	4
Manufacturer's address.....	4
Documentation manager.....	4
<b>Safety</b> .....	<b>5</b>
Intended use.....	5
Note regarding residual dangers .....	5
'E-Drive ultimate' braking system.....	5
Personnel qualifications for installation .....	5
Personnel qualifications for connection .....	5
Personnel qualifications for use .....	6
Personal protective equipment .....	6
Basic safety notices.....	6
Avoiding damage to property and malfunctions .....	6
Structural features of notices warning of danger .....	7
Structural features of notices warning of damage .....	7
<b>Transporting</b> .....	<b>7</b>
<b>Description</b> .....	<b>7</b>
Task and function.....	7
Modes .....	8
Controls .....	8
Indicator lamps and signals .....	8
Safety functions .....	10
Required accessories .....	10
Model plates .....	11
<b>Installation</b> .....	<b>11</b>
Installing the control module.....	11
Installing the control handle and holding handle .....	12
<b>Connecting the drive unit</b> .....	<b>13</b>
<b>Commissioning</b> .....	<b>13</b>
<b>Operation</b> .....	<b>14</b>
Switching on .....	14
Using the drive switch .....	14
Using 'Continuous driving' mode.....	15
Using 'Starting aid' mode.....	15

Activating the EMERGENCY STOP .....	15
Switching on again after EMERGENCY STOP .....	15
Switching the control to Standby mode .....	16
Switching off the control .....	16
Installation position .....	16
<b>Charging the rechargeable battery pack .....</b>	<b>17</b>
<b>Cleaning.....</b>	<b>18</b>
<b>Rectifying malfunctions .....</b>	<b>18</b>
Behaviour in the event of malfunctions and faults .....	18
Malfunction table .....	19
<b>Servicing and maintenance.....</b>	<b>21</b>
<b>Disposal.....</b>	<b>21</b>
<b>Technical data .....</b>	<b>22</b>
<b>Dimensioned drawings .....</b>	<b>23</b>
Dimensioned drawing of control module .....	23
Dimensioned drawing of control handle .....	24
Dimensioned drawing of holding handle.....	25

## Foreword

These operating instructions will help you to use the 'E-Drive ultimate' control system properly, safely and economically. It is used to control the 'E-Drive ultimate' drive unit. These operating instructions describe the 'E-Drive ultimate' control system for the 'E-Drive ultimate' drive unit as the 'control system' or 'control' for short. The 'E-Drive ultimate' drive unit is referred to as the 'drive unit' for short.

These operating instructions are intended for any persons installing, connecting and using this control system. In particular, they are aimed at fitters of vehicle body manufacturers and drive unit users.

It is the responsibility of all such persons to take note of and understand the content of these operating instructions. Following the information in these operating instructions will help to avoid hazards and to increase the reliability and the service life of the unit. In addition to the information in these operating instructions, always observe the statutory and other regulations that apply at the place of installation, e.g.:

- Accident prevention regulations
- Regulations governing safe and professional working.

### Availability

The operating instructions are part of the control system.

- Always store these operating instructions at the location where the control system is used.
- Make sure that the operating instructions are available to the user at all times.
- Enclose these operating instructions if you sell the control system or pass it on in any other manner.

### Other applicable documents

Other tips, directions and information can be found in the drive unit installation instructions. The installation instructions for the drive unit form part of these operating instructions. Keep the installation instructions together with these operating instructions. Include the installation instructions for the drive unit if you sell or otherwise pass on the control system.

### Structural features in the text

Specific design features are assigned to the different elements in these operating instructions. They make it easy to distinguish between the following elements:

Normal text

- Lists

➤ Steps to follow

- ① Tips that provide additional information such as special notes on economic use.

### Figures

All the figures in this manual are provided as examples.

### Copyright

These operating instructions contain information that is subject to copyright. Do not copy, print or adapt these operating instructions to film or reproduce, process, reproduce or disseminate them with any other method, whether in full or in part, without prior written consent from TENTE-ROLLEN GmbH.

© 2021 TENTE-ROLLEN GmbH

All rights reserved.

### Manufacturer's address

If you require further information, please contact the manufacturer:

TENTE-ROLLEN GmbH  
 Herrlinghausen 75  
 42929 Wermelskirchen, Germany  
 Phone: +49 (0) 21 96 / 99-0  
 Fax: +49 (0) 21 96 / 99-127  
 Email: info.de@tente.com  
 Web: www.tente.com

Information on the responsible sales partner can be found on the Internet at [www.tente.com](http://www.tente.com).

### Documentation manager

Karsten Schmitz  
 TENTE-ROLLEN GmbH  
 Herrlinghausen 75  
 D-42929 Wermelskirchen

## Safety

### Intended use

The control system's sole purpose is to control the drive unit. Other drives or motors must not be operated with this control system. The control system may only be used for commercial purposes indoors. It may only be used together with TENTE battery modules or external battery modules approved by TENTE GmbH.

Proper use also includes observing and following all information in these instructions, particularly the safety information and technical data.

Any use of the unit beyond this is not considered proper use.

The following tasks in particular are not considered proper use:

- Use in areas with slopes or gradients
- Driveless shunting / pulling of the frame with the drive unit lowered (e.g. 'tugger train' travel with the drive unit lowered)
- Use in areas where there is an explosion hazard
- Private use
- Outdoor use
- Use with power sources other than TENTE battery modules or battery modules with identical specifications
- Use in conjunction with a drive or motor that the manufacturer has not approved for use with this control system
- Use of the control system following unauthorised modifications
- Installation, connection and use by insufficiently qualified persons
- Use by unauthorised persons.

TENTE-ROLLEN GmbH accepts no liability for damage caused by improper use. Improper operation of the control system means that the manufacturer is not liable for material defects and voids the warranty.

### Note regarding residual dangers

The control system has been constructed according to the state-of-the-art and the recognised safety rules and relevant standards. Wherever possible, sources of danger have been eliminated in the design or ruled out with suitable facilities. Residual dangers may nevertheless arise upon use of the control system. Dangers to persons or impairment of the control system and other material assets can occur in particular if the control system:

- Is incorrectly installed, connected and commissioned by untrained personnel,
- Is not used properly,
- Is operated incorrectly.

### 'E-Drive ultimate' braking system

The control system and the associated drive unit are for driving support and shunting support. A brake function is activated by default. It can also be deactivated depending on the parameter settings. This brake function is always activated when the pressed drive switch (control handle) is released and is in the centre position. Deceleration is then initiated via a braking function (braking ramp) stored in the firmware (motor file).

The drive unit that is part of the control system has no impact brake or parking brake on the hardware side. If necessary, the operator must install a braking system on the unit being driven and is responsible for such a unit.

### Personnel qualifications for installation

The personnel authorised to install the device must have read and understood these operating instructions. They must also have specialist knowledge in the following areas:

- Installation of auxiliary electrical facilities
- Drilling holes and forming bolted connections.

### Personnel qualifications for connection

The personnel authorised to connect the device must have read and understood these operating instructions. They must also have specialist knowledge in the following areas:

- Making and testing electrical connections
- Properly routing electrical cables.

## Personnel qualifications for use

The control system users must have read and understood these operating instructions. They must also have specialist knowledge in the following areas:

- Use of transport vehicles, e.g. food distribution systems, laundry trucks or platform trucks
- Use of rechargeable battery chargers.

## Personal protective equipment

Make sure that the protective clothing specified for the relevant activity is worn during all work. The protective clothing must be selected according to the risks anticipated during the respective activity. In particular, the protective clothing must protect against the following risks:

- Injuries to the body
- Injuries to the hands
- Injuries to the feet.

## Basic safety notices

### Avoiding the risk of fatal injuries

Fatal injuries are possible due to electric shocks resulting from incorrect connection of the control system.

- Make sure that all connection work is performed by qualified personnel.
- Make sure that all connecting cables are routed properly.
- Make sure that the connecting cables are not damaged.
- Use only the enclosed connecting cables to connect the control system.
- Use only the TENTE rechargeable battery packs or rechargeable battery packs with identical specifications to supply power to the control system.

### Avoiding the risk of serious injuries

Risk of injury when driving due to limbs being pulled in.

- Wear close-fitting work clothing during operation. Do not wear any loose jewellery. Cover long hair with a hair net.

### Avoiding the risk of burns

The drive unit can generate intense heat. This can lead to burns if you come into contact with the drive unit.

- Do not touch the drive unit.

### Avoiding the risk of slight injuries

Crushing injuries can be caused by collisions with persons.

- During operation, make sure that no persons are located in the path of the transport vehicle.

## Avoiding damage to property and malfunctions

Damage to property can result if a drive other than the drive unit is used.

- Use the control system solely for controlling the drive unit.

Damage to property can result if the control system cables are not secured.

- Make sure that all connecting cables are properly laid.

Malfunctions can result if the connector is disconnected.

- Make sure that all connectors are plugged into the respective sockets.

Malfunctions can result if the components are insufficiently secured.

- Tighten all mounting screws required for securing the components.

Damage to property and malfunctions may occur from outdoor use.

Dirt and moisture can impede the function and result in damage to the control system.

- Use only cleaning agents that will not damage the materials of the control system. Consult your sales partner on this matter.

**Structural features of notices warning of danger**



**DANGER**

Notices containing the word DANGER warn of a hazardous situation which may possibly lead to death or severe injuries.



**WARNING**

Notices containing the word WARNING warn of a hazardous situation which may possibly lead to death or severe injuries.



**CAUTION**

Notices containing the word CAUTION warn of a situation which may lead to slight or moderate injuries.

**Structural features of notices warning of damage**

**ATTENTION!**

These notices warn of a situation that leads to damage.

**Transporting**

- Transport the control system in the original packaging.
- If the original packaging is not available, package the control system so that it is protected against moisture and mechanical damage.

**Description**

**Task and function**

The control system’s purpose is to control the drive unit. Its main elements are a control module (4), a control unit (1, 2), connecting cables with connector plugs (not shown) and a battery module for the power supply (not included in the scope of delivery).

The control module is connected to the drive unit via the supplied control line and controls its electric drive. The battery module supplies the components of the control system with 24 V direct voltage.

Operation is via a drive switch and an ON/OFF push-button. These operating elements are integrated into the control handle (2) of the control unit.

Use the ON/OFF push-button to switch on the control system. When not in use, the control system automatically switches itself off depending on the parameter settings. For more information on the modes, refer to the *Modes* section from page 8.

On the control handle, there are two LED lamps that indicate the system and battery status during operation. More information on this can be found in the *Indicator lamps and signals* section from page 8.

The control module has a service interface (3) for firmware updates or parameter changes.

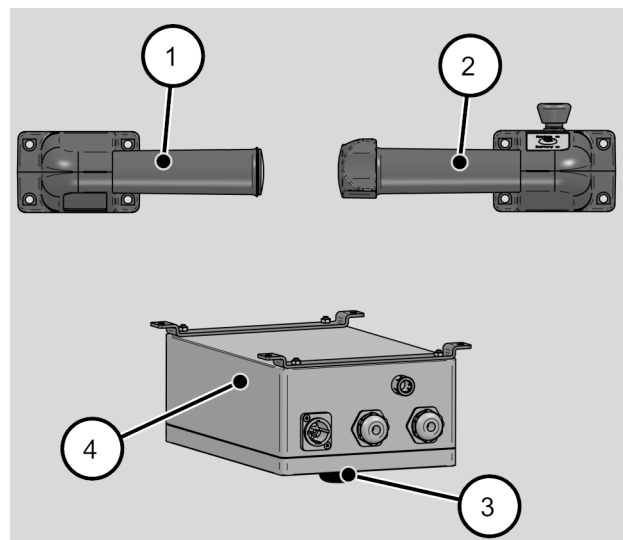

## Modes

The control system can be used in 'Continuous driving' mode or optionally in 'Starting aid' mode. However, only one mode is activated at a time. The mode in which your control system is operated depends on the respective configuration.

- The configuration may only be changed by TENTE-ROLLEN GmbH or upon receipt of written approval from TENTE-ROLLEN GmbH.

### 'Continuous driving' mode

The prime purpose of the drive unit is as a driving aid for your means of transport. In 'Continuous driving' mode, you can use the drive unit without interruption.

After the vehicle is parked or stopped, the drive unit remains on the ground depending on the parameter settings and then starts up again automatically.

### 'Starting aid' mode

In 'Starting aid' mode, driving support is limited. Once the pre-set time elapses, the control module switches off the drive unit and starts up the drive automatically. You can use the starting aid again after a few seconds.

## Controls

All of the operating elements are located on the control handle (4). Use the drive switch (1) to move the frame forwards or backwards. Use the ON/OFF push-button (2) to switch the control system on/off.

Use the EMERGENCY STOP switch (3) to interrupt the supply voltage from the driving motor and servo motor.

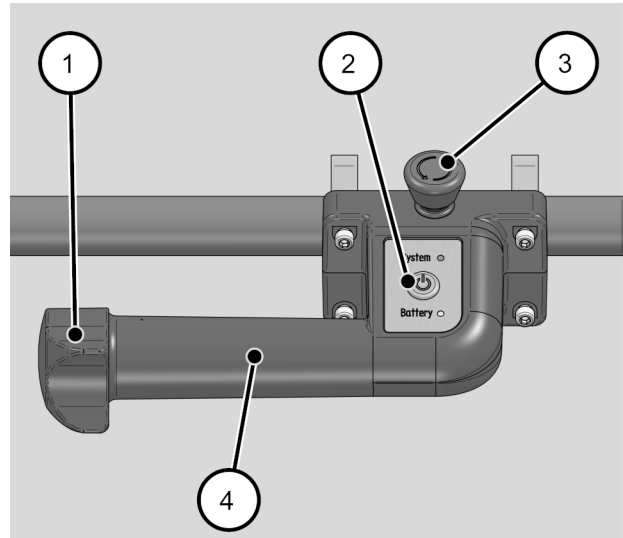





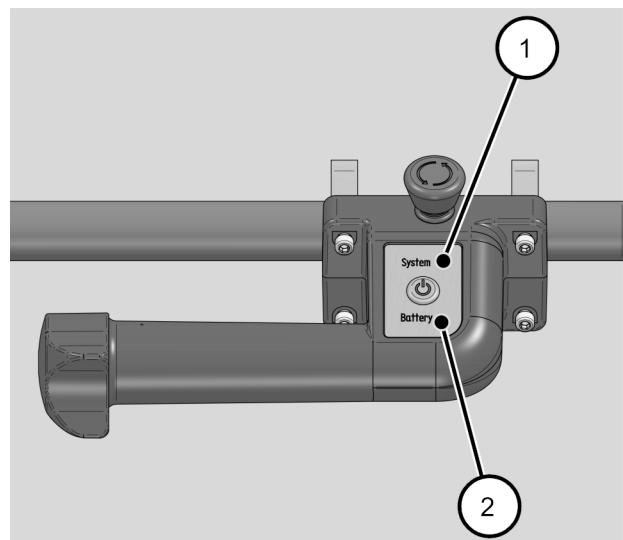







## Indicator lamps and signals

Two status indicators are located on the control handle. The System LED lamp (1) indicates the operating mode of the control system. The Battery LED lamp (2) provides information on the charge level of the rechargeable battery pack. An acoustic warning signal also sounds if there is a fault or the rechargeable battery is flat. The following table provides an overview of all status indicators and warning signals:





Status	Audible signal	LED status indicators	
Initialisation			System lights up red
Fault	Interval		System flashes red
EMERGENCY STOP is activated			System flashes red
Release the EMERGENCY STOP	Interval		System flashes red
Operational readiness			System lights up green
Driving/drive lowered			System flashes green
Mandatory break			System flashes yellow
Installation position/referencing			System lights up yellow
Battery is flat	Interval		Battery flashes red
Battery is over 80% charged			Battery lights up green
Battery is less than 80% charged			Battery lights up yellow
Battery is less than 60% charged			Battery lights up red
Battery is less than 50% charged	Interval		Battery flashes red

The battery indicators and the behaviour of the system apply only to the TENTE lithium-ion battery. When using third-party batteries (lead-gel or lithium-ion), the battery indicator and the system behaviour may deviate from the state and function.

## Safety functions

The control system has the following safety functions:

- The control has been tested and conforms to the relevant standards as per EN 13849-1, Performance Level 2
- Monitoring of the electronic switching systems
- Monitoring of the operating parameters
- Monitoring of the operating temperature
- EMERGENCY STOP according to category 0
- Tugger train function

The following measures prevent unwanted starting of the drive unit:

If the drive switch is pressed during switch-on, the control system emits an audible signal and the System LED flashes. In this case, the error message must be acknowledged by pressing the ON/OFF push-button. The drive switch must be in the centre position.

Unintentional activation of the drive unit in the installation position is prevented by the drive switch having to be rotated as far as possible for three seconds before the drive unit is started up.

Protection for externally driven driving motor in Standby mode:

If the speed recognition in Standby mode detects a driving motor movement, the routine checks over 11 seconds whether the driving motor is still moving. To counteract any defects caused by overvoltage or by recuperation, the control is switched on to raise the drive. After that, the control is put back into Standby mode. A signal sounds after approx. 6 seconds too.

Protection for an externally driven driving motor when switched on:

If the speed recognition detects a driving motor movement when switched on, the routine checks over 11 seconds whether the driving motor is still moving. To counteract any defects caused by overvoltage or by recuperation, the control raises the drive. A signal sounds after approx. 6 seconds too.

## Required accessories

The following components not included with the scope of delivery are also required to operate the control system:

- Battery module
- Connecting cable for the battery module
- Battery charger

- Control unit with holding handle and control handle
- Connecting cables with connector plugs
- Attachment accessories.



### CAUTION

Fire hazard if unauthorised lithium-ion batteries are used.

- Use only lithium-ion batteries that have been tested and approved by TENTE-ROLLEN GmbH.

### CAUTION!

System defects possible if unauthorised lithium-ion batteries are used.

- Use only lithium-ion batteries that have been tested and approved by TENTE-ROLLEN GmbH.

The battery module supplies the control system with the required voltage. You can use TENTE battery modules or alternative products with identical specifications.

To charge the batteries, you can use the TENTE charger or an alternative product with identical specifications. Consult TENTE-ROLLEN GmbH in all cases if you'd like to use alternative products.

The control unit can be installed both on a surface or on a tube. The control module must be fitted on a flat surface. The attachment accessories depend on your individual purpose.

You require four clamping brackets and four clamping blocks to install the control unit on tubes. TENTE-ROLLEN GmbH can supply you with the corresponding attachments sets for the following tube diameters:

- 27 mm – 31 mm
- 31 mm – 35 mm.

You require four clamping blocks to install the control unit on flat surfaces. These are also available from TENTE-ROLLEN GmbH.

You must also provide the following installation accessories:

- Screws for securely fastening the control module.
- Suitable means for securely attaching the connecting cables and plugs.

### Model plates

The model plates are located on the control module housing and the control handle. The model plates contain the following information:

- Manufacturer's address
- Serial number
- Supply voltage
- Protection class.

### Installation

The installation method depends on the type of chassis where the control system components are to be mounted. The following explanations on installation are therefore only examples.

**i** The section entitled *Dimensioned drawings* from page 23 contains dimensioned drawings of all enclosed control system components. Use this information to prepare the respective installation locations.

---

#### **CAUTION!**

The control system can be damaged as a result of incorrect installation.

- Make sure that the control system is installed by qualified specialist personnel.

---

#### **CAUTION!**

The control system can be damaged due to an unsuitable installation position.

- Select an installation position in which the control module cannot be damaged during subsequent movement.
- 

### Installing the control module

The control module must be attached to the frame with four screws. Two mounting brackets with four holes (1) are provided on the underside of the control module for this purpose. The holes have a diameter of 5.5 mm.

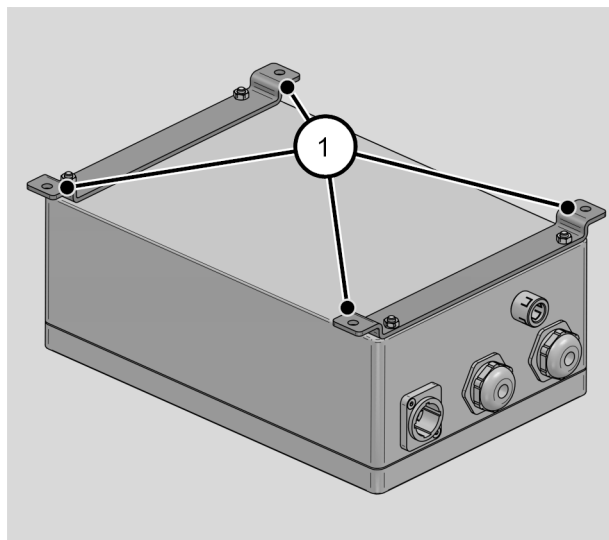

You may require the following tools and materials for installation:

- Drill
- Drill bits
- Spanner or screwdriver
- 4 suitable bolts
- 4 suitable snap rings.

Proceed as follows to install the control module on your chassis:

- Select an installation position in which the control module cannot be damaged during movement.
- Note the installation height of 93 mm.
- Drill the required holes if necessary.

The precise dimensions can be found in the illustration on page 23.

- Bolt the mounting plate of the control module to your chassis using suitable bolts.
- Make sure that the control module is securely bolted.

## Installing the control handle and holding handle

The control handle and the holding handle are intended for installation on either flat surfaces or tubes. Both installation options will be explained in the following section using the example of the control handle.

### Installing on a flat surface

The following tools and materials are required to mount the control handle on a wall:

- Appropriate drilling tool
- 6 mm drill
- 4 screws
- 2 clamping blocks
- Spanner
- Threaded nuts.

The clamps are available as accessories from TENTE-ROLLEN GmbH.

Proceed as follows to install the control handle on a flat surface:

➤ Drill the required holes.

The precise dimensions can be found in the illustration on page 24.

➤ Insert the clamping blocks (A) into the control handle (1).

➤ Fasten the control handle with the corresponding bolts.

➤ Make sure that the control cable is not trapped or damaged in any other way.

➤ Make sure that the control handle is firmly bolted.

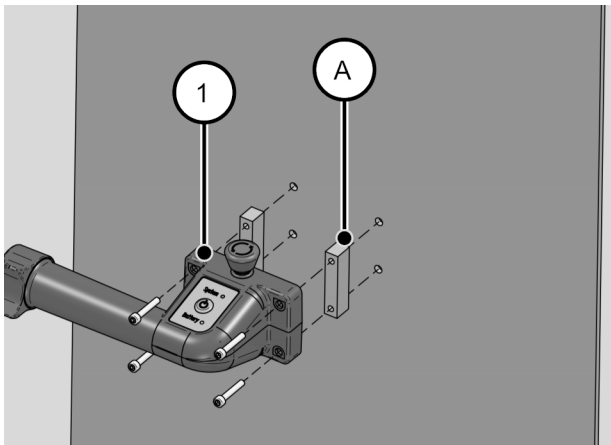

### Installing on a tube

The following tools and materials are required to mount the control handle on a tube:

- Spanner
- 2 clamps (A)
- 2 clamping brackets (B)
- 4 screws.

ⓘ Fastening sets consisting of clamping brackets and clamping blocks for tubes with diameters of 27 mm to 31 mm and 31 mm to 35 mm can be ordered from TENTE-ROLLEN GmbH as accessories. You will have to manufacture clamping brackets for other tube diameters by yourself or request them from TENTE-ROLLEN GmbH.

Proceed as follows to install the control handle on a tube:

➤ Insert the clamping blocks (A) into the control handle (1).

Position the control handle (1) on the tube.

➤ Firmly bolt the control handle to the clamping brackets (B).

➤ Make sure that the control handle is firmly bolted.

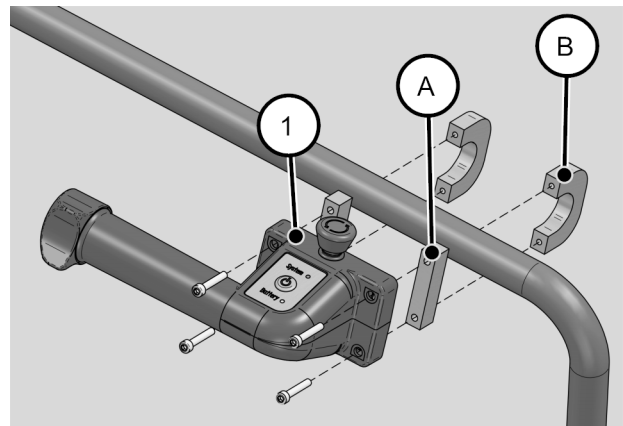

➤ To comply with the specifications as per the IPX4 protection class, observe the horizontal installation position shown below.

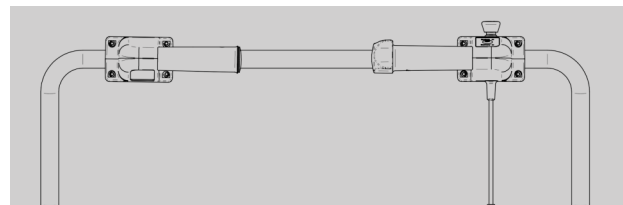

## Connecting the drive unit

The following connections must be made to connect the control system:

- 2 control cables with the drive unit
- Control handle with the control module
- Battery module with the control module.

All connections are made using corresponding connectors. The required cables and connectors are already installed on the control module and the control handle. A separate connecting cable is required for the connection between the rechargeable battery pack and the control module. A suitable connecting cable is available as an accessory from TENTE-ROLLEN GmbH.

The following connections can be found on the control module:

- Power supply connection (1).
- Connection for the control handle (2)
- Connections for the drive unit (3).

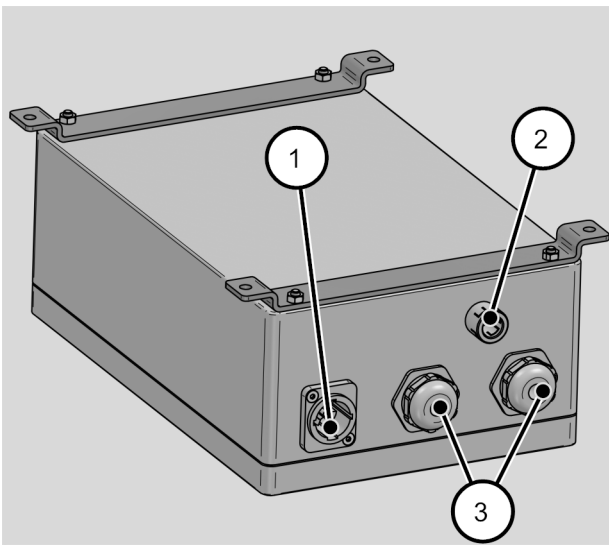

### **CAUTION!**

Damage to the control system as a result of improperly executed electrical installation.

- Make sure that the control system is installed by qualified specialist personnel.
- Make sure that cables and connectors cannot be torn off or be damaged in any other manner.

- Make sure that all components are properly installed.
- Connect the control module to the control connections of the drive unit.
- Connect the control handle with the plug of the pre-installed control cable to the connection (10) of the control module.
- Connect the battery module to the power supply connection (9) of the control module.

The connecting cable for the battery module is available separately from TENTE-ROLLEN GmbH.

- Secure the battery, the cables and the plugs using suitable fixtures to prevent possible breaking-off or other damage.
- Make sure that the cables cannot be damaged during driving.

## Commissioning

- Make sure that the battery module is fully charged.
- Switch on the battery module.

The following steps are performed only during the initial start-up.

The control system is initialised. During initialisation, the System LED lights up red. When this process is complete, the System LED switches off and the Battery LED indicates the current battery status. The control system is now in the 'Standby' operating state.

- To switch on the control system, press the ON/OFF push-button for at least 2 seconds.

The System LED lights up yellow.

- Turn the drive switch as far as possible and keep it in this position.

The drive unit is started up after approx. 3 seconds.

- Release the drive switch again to bring it into the home position.

The System LED then lights up green and indicates that the control system is in the 'ready for operation' operating state.

## Operation



### WARNING

Danger of fire and explosion.  
Manual movement with the drive unit lowered causes high reverse currents at travel speeds of > 3 km/h.

These can permanently damage the battery to the point of causing a fire or explosion, particularly when lithium-ion-batteries are used.

- Never move the frame manually with the drive unit lowered.

All of the control system's operating elements are located on the control handle. You use the ON/OFF push-button to switch on the control system and change to the corresponding mode. You use the drive switch to determine the starting direction and speed. If you would like to move a heavily loaded transport trolley, you must move the drive switch far enough until it reaches the desired direction of movement. If you only need to transport a small load, turn the drive switch only slightly.

### Switching on

- Switch on the battery module.

The control system is initialised. The control system is initialised. During initialisation, the System LED (1) lights up red. When this process is complete, the System LED (1) goes out and the Battery LED (3) indicates the current battery status. The control system is now in the 'Standby' operating state.

- To switch on the control system, press the ON/OFF push-button (2) for at least 2 seconds.

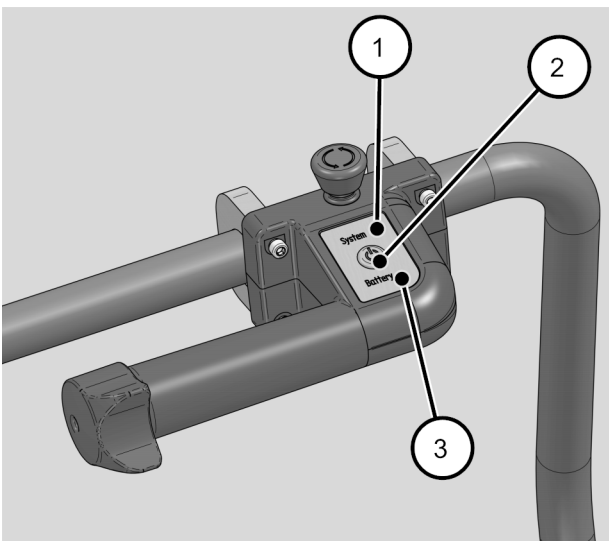

### Using the drive switch

Turning the drive switch (1) automatically moves the drive unit down. If you turn the drive switch (1) forward (A), you move the drive unit forward. Turning the drive switch (B) back reverses the drive unit. You can steplessly control the drive speed when doing this. Turning the drive switch as far as possible in the respective direction achieves the maximum speed. Driving stops in the centre position.

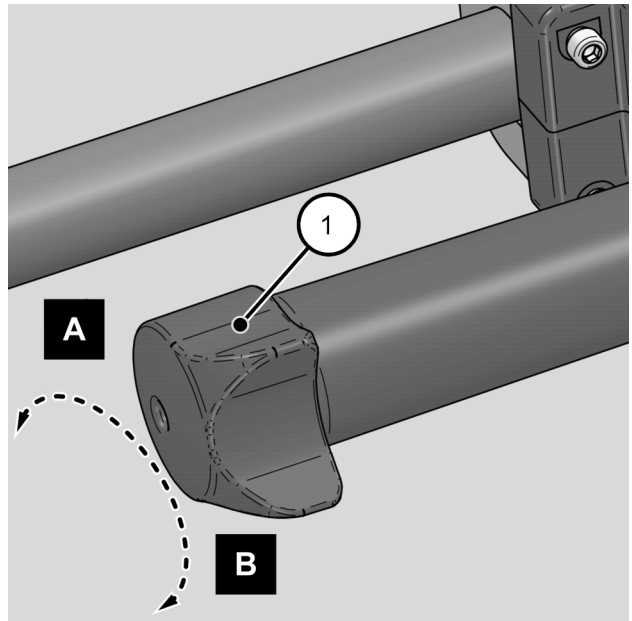

## Using 'Continuous driving' mode



### WARNING

The drive unit can generate intense heat in 'Continuous driving' mode. Severe burns may occur if you come into contact with the drive unit (driving motor).

- Do not touch the drive unit.

- Turn the drive switch (4) in the desired direction (A, B) to move the frame.

The drive unit moves down and starts.

- If you have to move a light weight, turn the drive switch only slightly.
- If you have to move a heavy weight, turn the drive switch correspondingly further.
- Turn the drive switch as far as possible in each case to obtain the maximum driving power.
- Release the drive switch if you have to interrupt driving

After the vehicle is parked or stopped, the drive unit remains on the ground depending on the parameter settings and then starts up again automatically.

## Using 'Starting aid' mode

Proceed as follows to use the drive unit in the optional 'Starting aid' mode:

- Turn the drive switch (4) in the desired direction (A, B).
- If you must move a light weight, turn the drive switch only slightly.
- If you must move a heavy weight, turn the drive switch correspondingly further.
- Turn the drive switch as far as possible in each case in order to obtain the maximum driving power.

The drive unit moves down and starts. The system LED lamp flashes green.

After the pre-set drive time expires, the drive unit is raised automatically and pauses.

- Release the drive switch (4) if you want to manually interrupt the drive time.

## Activating the EMERGENCY STOP



### WARNING

When the EMERGENCY STOP switch is activated, the frame is not braked, and neither is the deceleration function activated by default. The frame may roll out and cause injuries.

- Make sure that the frame does not roll out.
- Stop the frame manually if necessary.

- Press the EMERGENCY STOP switch.

The supply voltage from the driving motor and servo motor is interrupted.

## Switching on again after EMERGENCY STOP

- Release the EMERGENCY STOP switch.

The System LED flashes red and a signal sounds.

- To acknowledge the EMERGENCY STOP situation, press the ON/OFF push-button.

When the drive unit is lowered, the System LED lights up yellow.

- To move the drive unit to the home position, you must hold the drive switch in one direction of movement for 3 seconds before starting up again.

When the drive unit is in the home position, the System LED lights up green. The drive unit is ready for operation.

## Switching the control to Standby mode

### **CAUTION!**

Damage to the battery module due to deep discharge in Standby mode.

- Always disconnect the power supply when not in use.

In normal mode:

The drive unit is in the home position (folded). The System LED continuously lights up green.

- Press the ON/OFF push-button for at least three seconds.

The System LED on the handle goes out. The Battery LED continues to indicate the battery level. The control is in Standby mode.

If an error occurs:

- Press the ON/OFF push-button.

The control switches to Standby mode.

The system also automatically switches to Standby mode when:

- the preset switch-off time is reached
- there is an error (after 60 seconds)
- the battery is flat.

 The control module's standby time is switched off at the factory. It can be switched on or changed if desired.

 The configuration may only be changed by TENTE-ROLLEN GmbH or on receipt of written approval from TENTE-ROLLEN GmbH.

## Switching off the control

Switch the system off completely when it is not in use.

To do this, proceed as follows:

- On the TENTE battery module, turn the key on the battery to the OFF position.

The system is now voltage-free. No LED lights up on the handle.

## Installation position

If the control has been switched off using the battery and the drive unit is in the 'bottom' position, the control changes to the 'installation position' state when switched back on again.

- To move the drive unit to the home position, hold the drive switch in one direction of movement for three seconds.

When the drive unit is in the home position, the System LED lights up green. The drive unit is ready for operation.



## Charging the rechargeable battery pack



### WARNING

Risk of explosion from incorrect charging of the battery.

If you charge the battery with the top side facing downwards, gases are produced inside it that can cause an explosion.

- Always charge the battery with the top side facing up. For this, pay attention to the corresponding direction arrow on the battery.



### CAUTION

Fire hazard if unauthorised lithium-ion batteries are used.

- Use only lithium-ion batteries that have been tested and approved by TENTE-ROLLEN GmbH.

### CAUTION!

System defects possible if unauthorised lithium-ion batteries are used.

- Use only lithium-ion batteries that have been tested and approved by TENTE-ROLLEN GmbH.

The maximum possible battery module operating period depends on its use. The battery module must be charged as soon as the unit has switched itself off automatically and the battery LED lamp (1) flashes red. The current charge is indicated by the battery LED lamp (1) on the control handle.

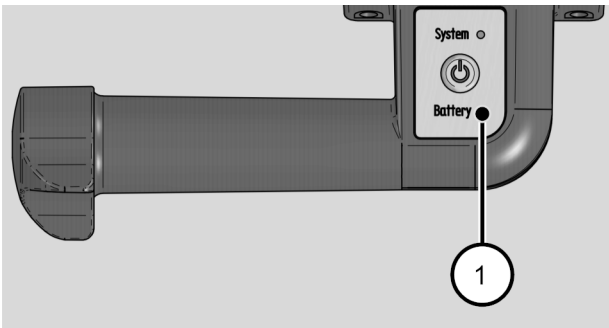

- ⓘ The battery in the battery module wears out over time. This increasingly reduces its charging capacity. If the charging capacity is no longer sufficient for efficient operation, you must replace the battery module with a new one of the same type.

If the battery module capacity has reached the discharge limit, the Battery LED lamp (1) flashes red. An audible signal is also emitted at intervals. The control can then either be switched off by pressing the ON push-button, or the control switches itself off automatically after 60 seconds. The last 'Battery discharged' state is stored and the control is only ready for operation again when the battery voltage is above 60%. If the value is below this limit, the user is informed that the battery is still discharged (red flashing battery indicator on the handset). The drive cannot then be activated. The aim is to prevent the user from starting the drive repeatedly with a discharged battery.

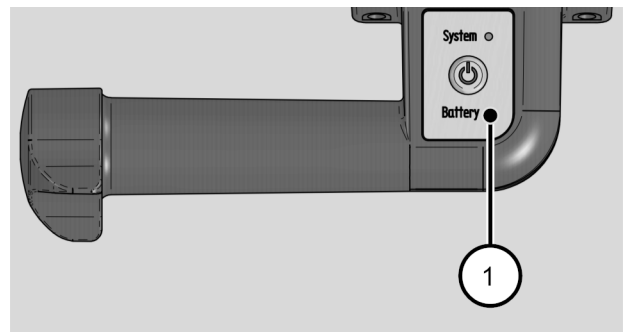

- To charge the battery module, disconnect the control system from the power supply through the battery module.
- To do this, pull out the plug on the battery module.
- Connect a suitable charger to the battery module.

---

**CAUTION!**

System faults are possible if unauthorised chargers are used.

- Use only a charger suitable for the respective battery type.
- 

- Charge the battery module fully.
- Then insert the plug for the control system's power supply back into the corresponding socket on the battery module.
- Switch the control system back on after the battery module has charged.

---

## Cleaning

**CAUTION!**

Irreparable damage can be caused to the control system due to improper cleaning.

- Make sure that no fluid can enter the control system components during cleaning.
- 

For reliable and long-term operation, it is necessary to keep the control system components clean. External cleaning is sufficient for this.

- Clean the operating unit and the control module when they become soiled.
- Make sure that no moisture can enter the control system components during cleaning.
- Remove external soiling with a dry cloth or a cloth moistened with mild soap solution.

## Rectifying malfunctions

### Behaviour in the event of malfunctions and faults

If a fault has occurred, the system LED lamp flashes red and an audible warning signal sounds. Perform the following measures immediately:

- Disconnect the control module from the power supply through the battery module.
- Make sure that the cause of the fault is remedied by a qualified person.
- Do not put the control system back into operation until the fault has been remedied.

If the drive unit is in the bottom position after the fault has been remedied, the control system must be re-initialised before use. To initialise, proceed as follows:

- Switch on the battery module.

The control system is initialised. During initialisation, the System LED lights up red. When this process is complete, the System LED switches off and the Battery LED indicates the current battery status. The control system is now in the 'Standby' operating state.

- To switch on the control system, press the ON/OFF push-button for at least 2 seconds.
- Turn the drive switch as far as possible and keep it in this position.

The drive unit is started up after three seconds.

- Release the drive switch again to bring it into the neutral position.

The System LED lamp then lights up green and indicates that the control system is in the 'ready for operation' operating state.

**Malfunction table**

Fault	Cause	Remedy
The control system is switched off while the drive unit is in the bottom position.	The drive unit is in the installation position. The power supply was interrupted during operation.	<ul style="list-style-type: none"> <li>➤ Switch on the battery module.</li> </ul> The following steps are performed only during the initial start-up. The control system is initialised. During initialisation, the System LED lights up red. When this process is complete, the System LED switches off and the Battery LED indicates the current battery status. The control system is now in Standby mode. <ul style="list-style-type: none"> <li>➤ To switch on the control system, press the ON/OFF push-button for at least 2 seconds.</li> <li>➤ Turn the drive switch as far as possible and keep it in this position.</li> </ul> The drive unit is started up after approx. 3 seconds. <ul style="list-style-type: none"> <li>➤ Release the drive switch again to bring it into the home position.</li> </ul> The System LED lights up green. The control system is ready for operation.
The control system cannot be switched on, the battery module cannot be charged	The fuse of the battery module is faulty	<ul style="list-style-type: none"> <li>➤ Make sure that the fuse is tested by a qualified electrician.</li> <li>➤ Replace faulty components completely.</li> </ul>
	The battery module is faulty	<ul style="list-style-type: none"> <li>➤ Make sure that the battery module is tested by a qualified electrician.</li> </ul>
The driving motor is not switched on	The cables are faulty.	<ul style="list-style-type: none"> <li>➤ Make sure that the cables are tested by a qualified electrician.</li> <li>➤ Replace faulty components completely.</li> </ul>
	The driving motor of the drive unit is faulty.	<ul style="list-style-type: none"> <li>➤ Make sure that the driving motor of the drive unit is tested by a qualified electrician.</li> <li>➤ Contact TENTE-ROLLEN GmbH if necessary</li> </ul>
	The control system is faulty	<ul style="list-style-type: none"> <li>➤ Make sure that the control system is tested by a qualified electrician.</li> <li>➤ Contact TENTE-ROLLEN GmbH if necessary</li> </ul>

Fault	Cause	Remedy
A fault is displayed when the drive unit is shut down.	The control system is faulty.	<ul style="list-style-type: none"> <li>➤ Make sure that the control system is tested by a qualified electrician.</li> <li>➤ Contact TENTE-ROLLEN GmbH if necessary</li> </ul>
	The cables are faulty.	<ul style="list-style-type: none"> <li>➤ Make sure that the cables are tested by a qualified electrician.</li> </ul>
	There is a mechanical fault in the drive unit.	<ul style="list-style-type: none"> <li>➤ Make sure that the drive unit is tested by an expert.</li> </ul>
A fault is displayed when the drive unit is raised. (Drive unit is raised and lowered twice, followed by System LED red + signal)	Micro-switch is not pressed.	<ul style="list-style-type: none"> <li>➤ Reset the micro-switch on the drive unit so that it is pressed during running-in.</li> </ul>
After switching on the system: System LED red and audible signal.	The control is faulty.	<ul style="list-style-type: none"> <li>➤ Contact TENTE-ROLLEN GmbH.</li> </ul>

## Servicing and maintenance

### **CAUTION!**

Irreparable damage can be caused to the control system due to the use of unsuitable replacement parts.

- Use only original replacement parts from TENTE-ROLLEN GmbH.

### **CAUTION!**

Irreparable damage can be caused to the control system as a result of incorrect repair work.

- Do not attempt any repair work on the control system components.
- Only exchange faulty components as complete units.

The control system components are maintenance-free. Never open the housing of the control module nor the housing of the control handle.

- Do not attempt any repair or maintenance work on the control system components.
- Make sure that faulty components are replaced completely with new original replacement parts from TENTE-ROLLEN GmbH.
- Make sure that faulty components are only exchanged by correspondingly qualified specialist personnel.

## Disposal



### **WARNING**

Poisoning and chemical burns due to improper disposal of lead and sulphuric acid.

- Make sure that the battery module is sent to the separate pollutant disposal facility.

The environmentally sound disposal of electronic assemblies, recyclable materials and other components is regulated by national and regional laws. Disposal in regular household waste is not permitted. Contact the appropriate local authority for detailed disposal information. You must sort the parts to dispose of all of them in an environmentally sound manner. Sort the parts as follows:

- Hazardous waste
- Electronic scrap
- Metals
- Plastics.

- Make sure that the battery module is sent to the separate pollutant disposal facility.
- Dispose of the other suitable parts for recycling.



## Technical data

Control module	
Supply voltage	24 V DC Final charging voltage: max. 29.4 V. Higher values only allowed after approval by TENTE-Rollen GmbH.
Power consumption at 24 V in Standby mode	0.4 A
Current consumption at 24 V with the driving motor switched on	15 A
Ambient storage temperature	-10 to +40 °C
Permissible ambient temperature for operation	0 to +40 °C humidity 90%, non-condensing
Protection class	IPX4 (splash water from all sides)

Control handle	
Supply voltage	24 V, DC
Power consumption at 24 V	0.05 A
Ambient storage temperature	-10 to +40 °C
Permissible ambient temperature for operation	0 to +40 °C humidity 90 %, non-condensing
Protection Class	IPX4 (splash water from all sides) with horizontal installation

## Dimensioned drawings

### Dimensioned drawing of control module

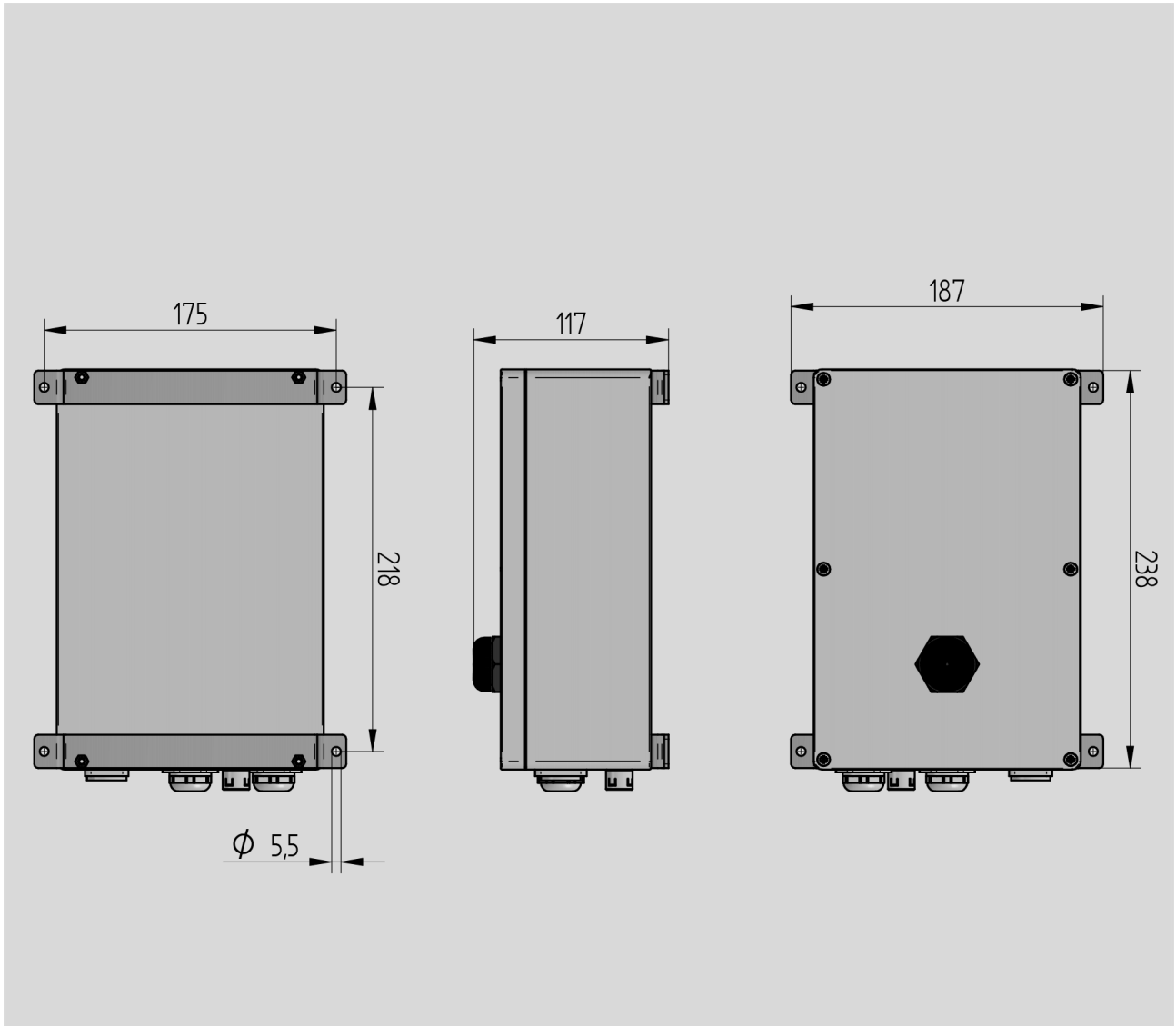

All dimensions given in mm.

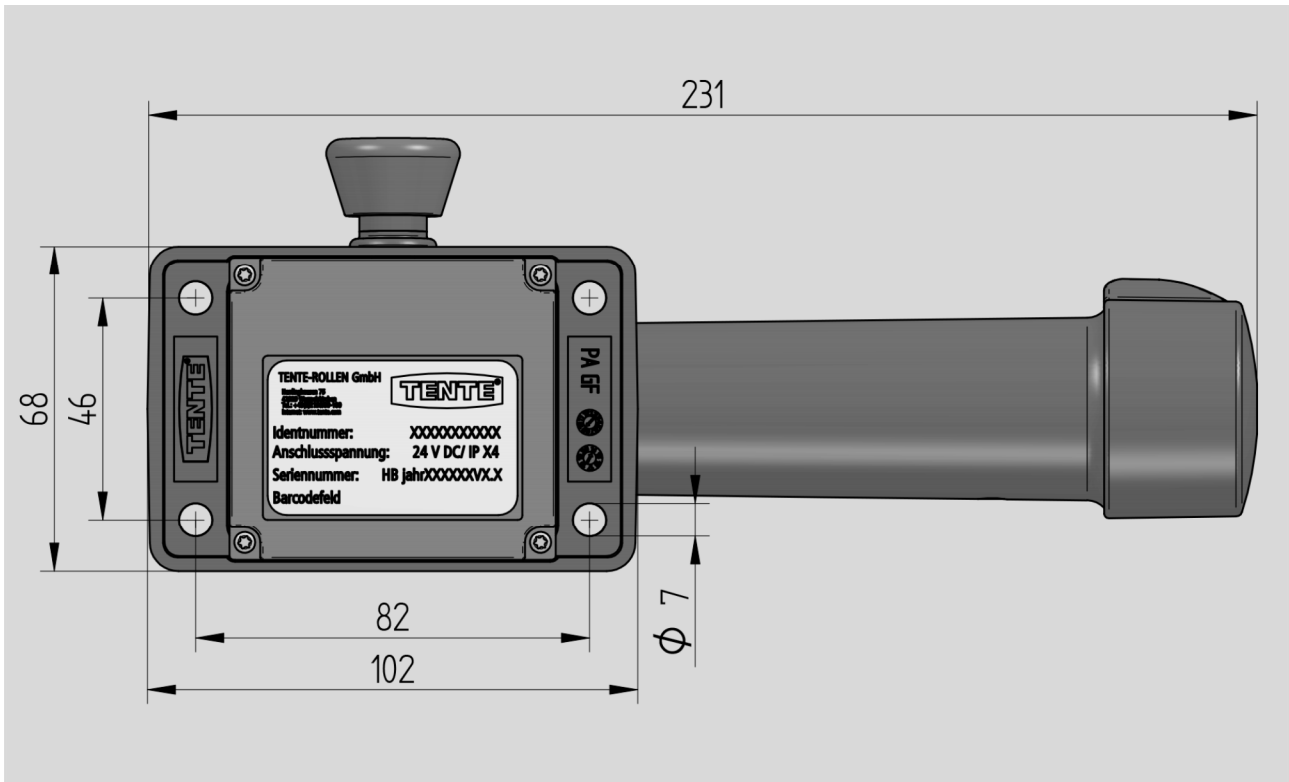
**Dimensioned drawing of control handle**

All dimensions given in mm.

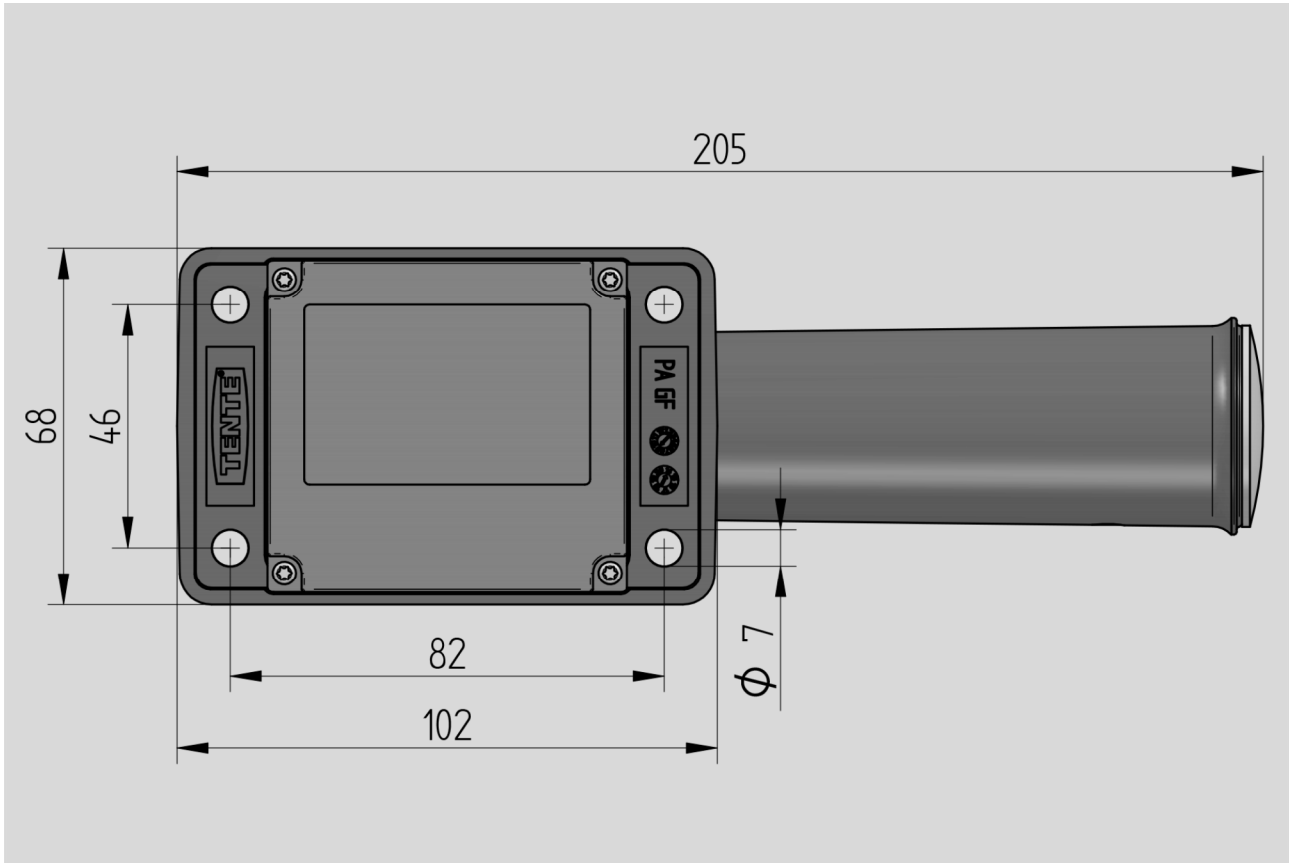

**Dimensioned drawing of holding handle**

All dimensions given in mm.