

# SOLUTIONS FOR THE CLEANING INDUSTRY INDIVIDUAL, HYGIENIC AND EFFICIENT



**TENTE**

BETTER MOBILITY. BETTER LIFE.



# PURE RELIABILITY

Whenever reliable castors and wheels are needed for cleaning equipment or heating and cooling systems, one name stands at the top of the preference list: TENTE. With us you can expect a wide range of solutions that are perfectly adapted to the specific operating conditions in restaurants, hospitals, hotels and office buildings. Whether for cleaning trolleys or air conditioning units, our castors and wheels are gentle on the floor and extremely easy to move. It makes no difference whether the trolleys have to be moved over longer distances or pushed back and forth in a confined space.

## **GENTLE ON THE ENVIRONMENT**

In industries where cleanliness and hygiene are essential, we have always led the way. We offer you non-marking wheels with reduced abrasion for clean and sensitive floors. If you need solutions for humid environments, we can offer you rustproof models and hydrolysis-resistant materials. You can also rely on products that are unaffected by many cleaning agents and chemical substances and do not cause contact discoloration even after long periods of use.

## **100 PER CENT SAFETY**

Our company's mobility solutions guarantee improved traction on wet floors, and are also known for their easy handling. Reliable locking devices ensure a secure stand and are recommended for air conditioning systems or heavy cleaning trolleys.

On the following pages you will find more information about our mobility solutions for the cleaning sector. Please feel free to contact us for further technical details or a personal consultation.

# DESIGN AND RUNNING COMFORT WITH LEVINA

📏 75 - 100 kg    🛠️ 103 - 194 mm    ⚙️ 75 - 150 mm

Hygienic and safe - the Levina castor is particularly suited for use in a hygienically sensitive environment such as the cleaning industry. With its plastic housing and soft, shock-absorbing tread, the Levina castor offers optimum handling, as well as safe and quiet movement.

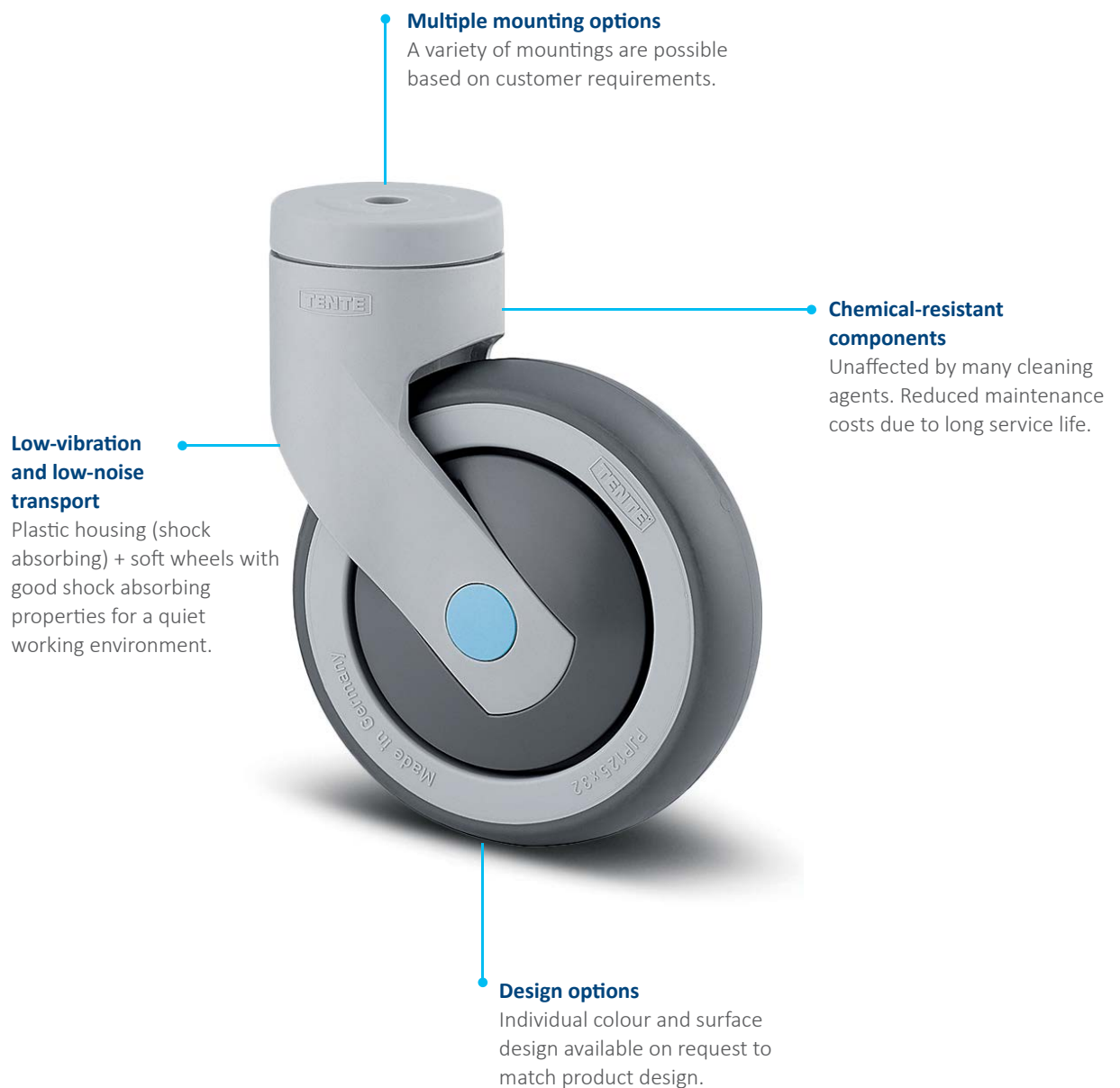

**CAUTION  
WET FLOOR**



# EFFICIENT & EASY WORKING WITH LINEA SAFETY

 **60 - 100 kg**    **81 - 111 mm**    **75 - 100 mm**

Optimise your work processes: the Linea safety system makes work processes even more efficient and safe. The locking of the castors by means of an actuation lever enables the device to be securely locked, preventing unwanted movements. The brake only releases when a pedal or handle is activated by the user.

## Work safety and control

The integrated dead man's brake locks multiple castors simultaneously via an actuation lever. The castors can only be moved when the user actively operates a lever or handle.

## Easy manoeuvrability

The differential effect of the twin wheel castor provides flexibility and ensures comfortable manoeuvring.

## Chemical resistant materials

Sealed bearings protect the wheels from dirt and spray water. They are unaffected by many cleaning agents and chemical substances.

## Individual look

The wheels can be printed with different images and produced in different colours at your request.

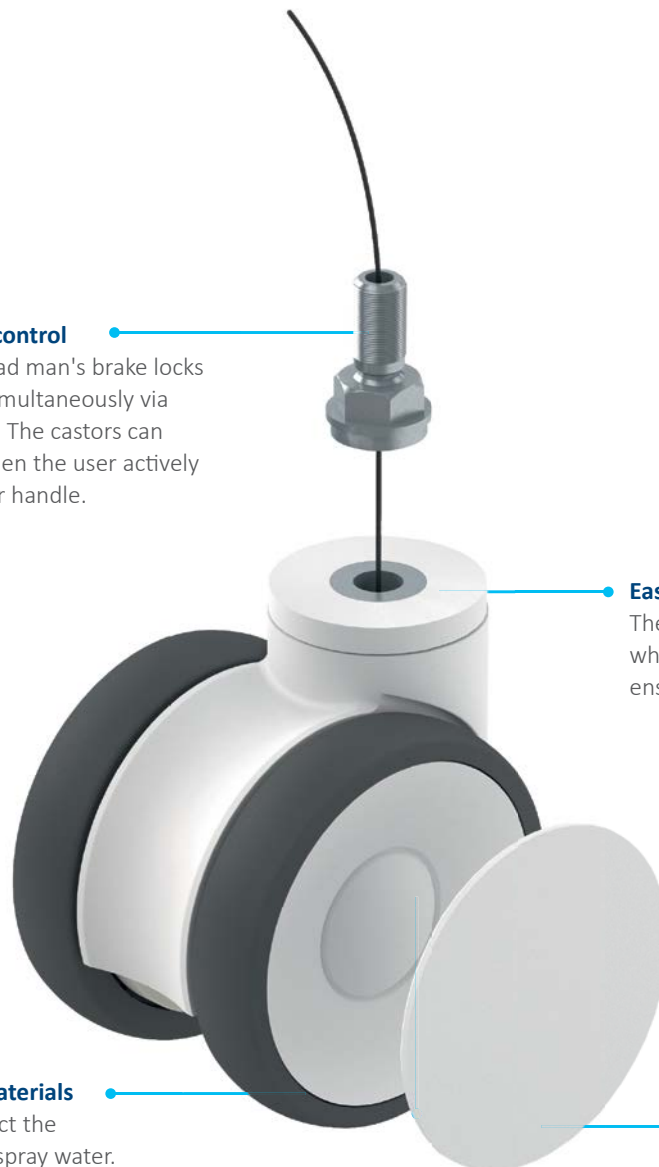

# SAFE WORK PROCESSES WITH ALPHA SAFETY

 **200 - 350 kg**    **200 - 240 mm**    **160 - 200 mm**

Alpha safety with an automatic locking system can only be moved if the user keeps the operating handle pressed. When the handle is released, the castors are automatically locked and the device is instantly brought to a safe stance.



# LONG-LASTING WITH AGILA

 **40 - 100 kg**    **58 - 188 mm**    **35 - 150 mm**

Ergonomics, handling stability and safety – the Agila wheel range is very well suited for extreme and diverse applications. Its robust and durable construction ensures long-lasting and low-maintenance performance.







# INDIVIDUAL USE WITH MONO

 **30 - 70 kg**    **72 - 120 mm**    **50 - 100 mm**

The soft wheels of the Mono castor are particularly shock-absorbing and ensure low-vibration and smooth transport. A large assortment of mountings in different sizes allows for use in diverse areas. Simple plug-in fittings speed up the assembly process. The Mono castor is unaffected by many chemical substances and is therefore ideal for use in the cleaning and hospital sector.

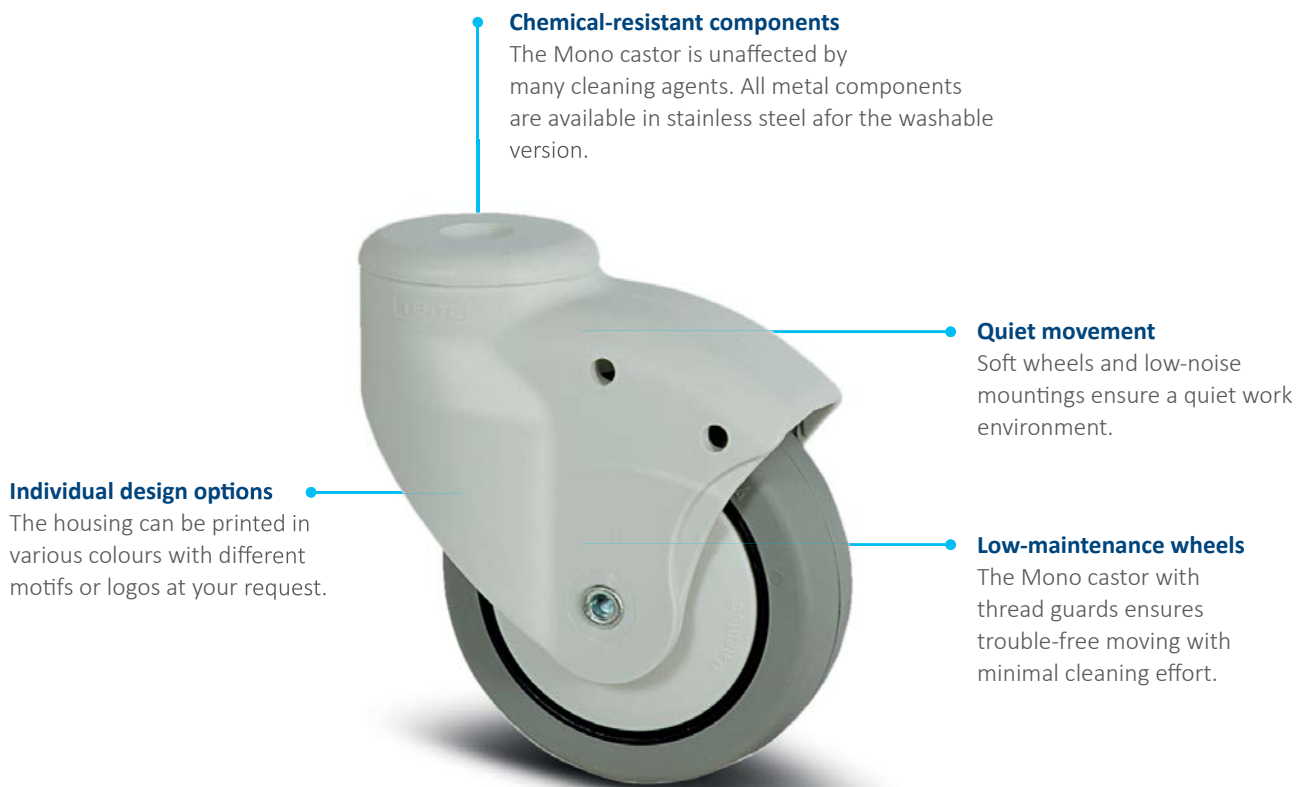

# NUMEROUS APPLICATIONS WITH SUPRATECH WHEELS

Smooth-handling all-rounders with thermoplastic rubber tread.

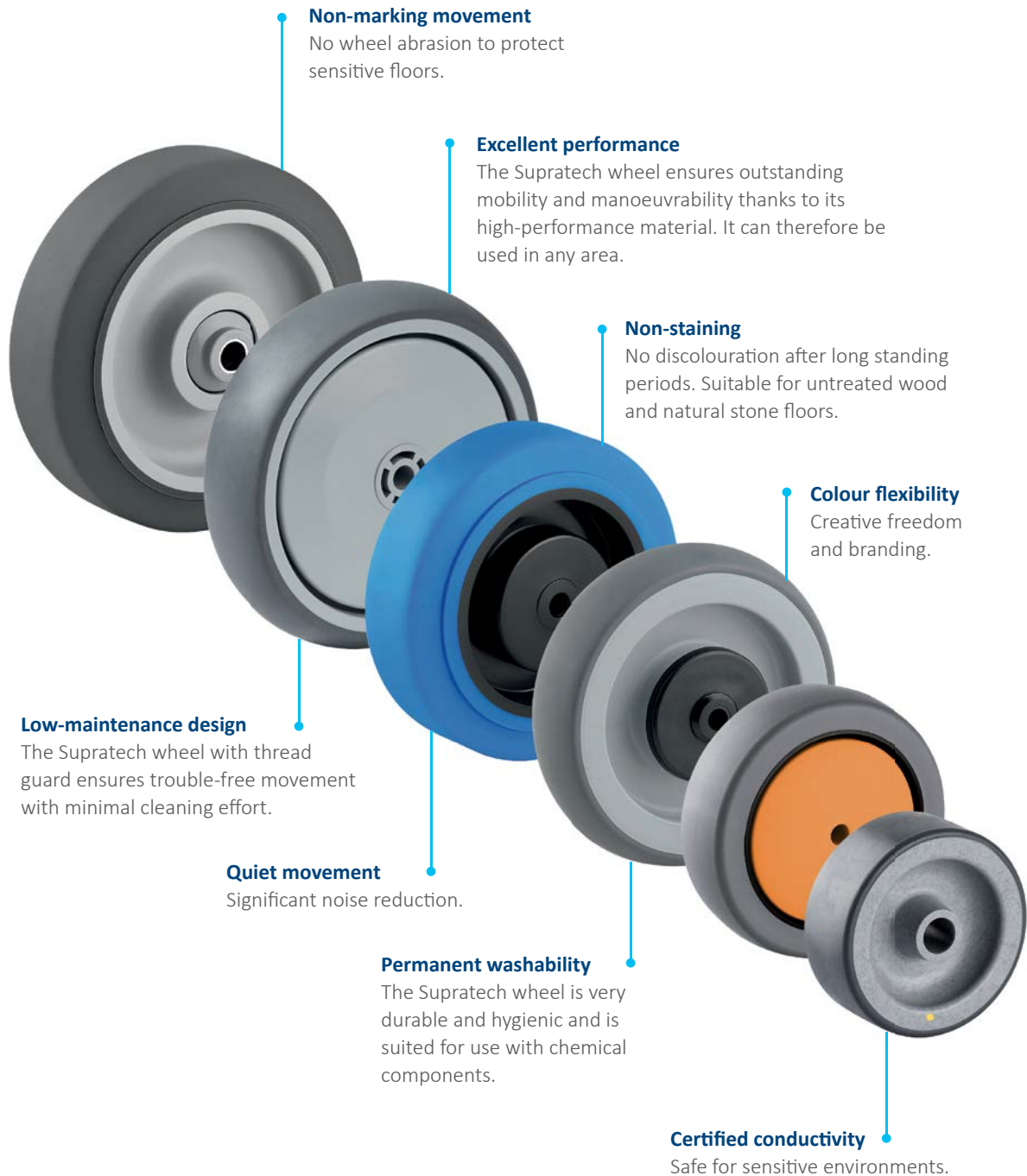

# LESS MAINTENANCE WITH DURATECH WHEELS

Our robust Duratech wheels, made of polyamide and duroplastic are stable and almost indestructible.



# SAVE TIME AND EFFORT WITH CENTRAL LOCKING SYSTEM

Using a central operating lever, multiple castors can be locked simultaneously, thereby increasing productivity and reducing the user's effort.



THE CENTRAL LOCK IS ALSO AVAILABLE FOR THE FOLLOWING PRODUCT FAMILIES:



**Alpha**

200 - 400 kg  
160 - 200 mm



**Delta**

540 - 600 kg  
160 - 200 mm

# EFFICIENT TRANSPORT WITH E-DRIVE

The smart solution, our electric drive system, also known as "E-Drive", allows employees to effortlessly transport a large volume of goods and not only improves productivity, but also enhances staff well-being and reduces operating costs.

## Practical system solution

Easy to integrate system solution consisting of drive unit, control module, manual operating unit, battery, charger and mounting set.

## High flexibility

The E-Drive system can be individually configured according to the customer's requirements. The system can be easily integrated into existing applications. In stand-by mode, the drive wheel is retracted so that the trolley can be moved manually.

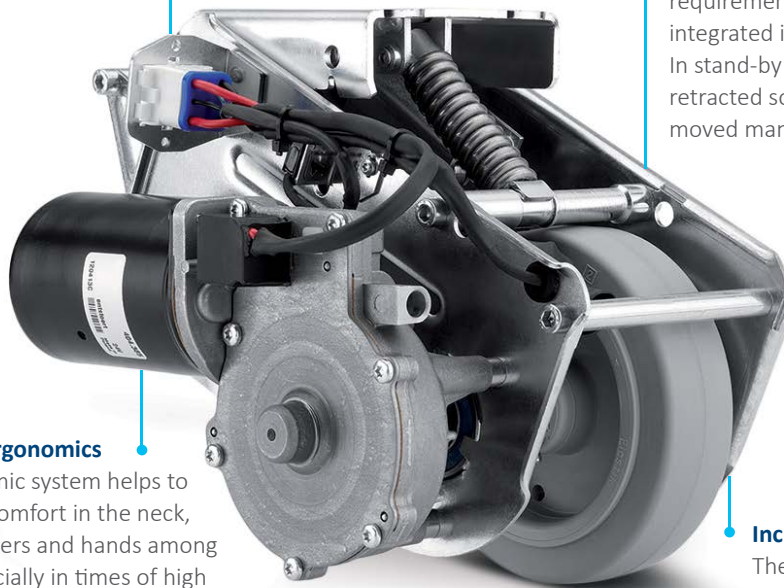

## Improved ergonomics

The ergonomic system helps to prevent discomfort in the neck, back, shoulders and hands among users - especially in times of high demographic change. Ergonomic handling and operation means fewer absences due to illness, allowing a quick regain of the initial cost of the E-Drive system.

## Increased productivity

The E-Drive makes operating processes more efficient, resulting in cost savings.



*"The electric drive boosts employee satisfaction and improves our service."*

Anne Elise Choux Operations Manager of Starling Hotels & Conference Centers Geneva

Read more about the customer reference:  
[www.tente.com/mercure](http://www.tente.com/mercure)



# DIVERSITY WITH A SYSTEM OUR CASTORS

All of our products have their own specific qualities and strengths. Whether it's high design standards, specialist applications or exceptional load capacities – our range can meet your needs and be adapted to fit different models.

From the correct dimensions and technical specifications to the required configuration, our product families are able to offer the ideal solution – whatever you need. Contact us for more information or visit our website: [www.tente.com](http://www.tente.com)

E-Drive



⌀ 125 mm

Alpha



⊃ 70 - 500 kg  
⌀ 80 - 200 mm

Delta



⊃ 300 - 600 kg  
⌀ 125 - 200 mm

Delta twin



⊃ 600 - 750 kg  
⌀ 125 - 200 mm

Zeta



⊃ 300 - 800 kg  
⌀ 125 - 250 mm

Kappa



⊃ 300 - 2.000 kg  
⌀ 80 - 300 mm

Kappa flex



⊃ 360 - 750 kg  
⌀ 160 - 200 mm

Omikron



⊃ 900 - 11.000 kg  
⌀ 100 - 500 mm



Radiata



1.200 - 1.500 kg  
80 mm

Scout



150 - 350 kg  
160 - 200 mm

Integral



100 - 150 kg  
100 - 200 mm

Integral twin



125 - 250 kg  
100 - 150 mm

Linea clinic



150 - 200 kg  
125 - 150 mm

Aviana care



100 kg  
75 mm

Aviana



75 mm

Agila



40 - 100 kg  
50 - 150 mm

Agila twin



50 - 100 kg  
50 - 75 mm

Stora



60 - 160 kg  
75 - 160 mm

Mono



30 - 70 kg  
50 - 100 mm

Galea



60 - 100 kg  
100 - 125 mm

Levina



60 - 100 kg  
75 - 150 mm

Linea



40 - 150 kg  
50 - 150 mm

Anika



40 - 50 kg  
55 - 75 mm

Lumina



30 - 100 kg  
35 - 75 mm

Stylea



40 - 100 kg  
35 - 100 mm

Smiles



40 kg  
50 mm

Compacta



10 - 55 kg  
14 - 50 mm

# EXPERTISE THAT INSPIRES

## CONTACT US

We are a globally operating company supporting you on five continents. This means on-site support with service on a level playing field – along with in-depth knowledge. Additionally, our solution experts will advise you on the best mobility concept for your needs. Go here to find your nearest TENTE location: [www.tente.com/locations](http://www.tente.com/locations)

## INCREASE YOUR EFFICIENCY

Our intelligent mobility solutions help you save time, effort, energy, and operating expenses. This allows you to improve your operating methods and working conditions, thereby optimising your processes and ensuring higher productivity, profitability and safety. Ask for our solutions catalogue or read about how our customers benefit from our tailor-made solutions on our website: [www.tente.com/solutions](http://www.tente.com/solutions)

## SAVE DEVELOPMENT TIME

On our website you will find technical drawings, product data sheets and 2D and 3D CAD files in various formats: [www.tente.com/products](http://www.tente.com/products)

## GET MORE INFORMATION

In addition to our informative website, you can easily download various catalogues and brochures on mobility solutions, customer references, and much more: [www.tente.com/download](http://www.tente.com/download)



ER LIFE.

ET



[www.tente.com](http://www.tente.com)



PRODUCTIVITY



SAFETY



DESIGN



DURABILITY



ENVIRONMENT