

E-Drive ultimate drive unit Installation instructions

06/2021

Translation of the original German installation instructions

TENTE

BETTER MOBILITY. BETTER LIFE.

Contents

Foreword	3
Availability	3
Structural features in the text	3
Copyright	3
Manufacturer's address.....	3
Safety	4
Intended use.....	4
Basic safety notices.....	4
Avoiding damage to property and malfunctions	4
Qualifications of personnel.....	5
Personal protective equipment	5
Structural features of notices warning of danger	5
Structural features of notices warning of damage	5
Description of the device	6
Scope of delivery and device overview.....	6
Task and function.....	7
Assignment of the connection sockets.....	8
Technical data.....	9
Transporting the device	10
Preparing installation	11
Creating the prerequisites for installation.....	11
Mounting the interface.....	11
Unpacking the device	12
Installing the device	12
Fastening the device.....	13
Connecting the device	13
Commissioning the device and testing its functioning	14
Commissioning the device	14
Setting the micro switch	14
Testing the functioning of the emergency release	15
Maintaining the unit	16

Foreword

These installation instructions will help you to install the 'E-Drive ultimate' electric drive unit properly, safely and economically. It is intended for installation on a frame prepared for this purpose. In these installation instructions, the electric drive unit is referred to as the 'unit' for short.

They are intended for anybody installing, connecting or maintaining this unit, particularly fitters working for frame manufacturers.

It is the responsibility of all these people to take note of and understand the content of these installation instructions. Following the information in these installation instructions will help to avoid hazards and to increase the reliability and the service life of the unit. In addition to the information in these installation instructions, always observe the statutory and other regulations that apply at the place of installation, e.g.:

- Accident prevention regulations
- Regulations governing safe and professional working

Availability

These installation instructions are a component of the device.

Always store them with the device's documentation. Ensure that they are available to the user.

If you transfer this device to another owner, you have to transfer these installation instructions as well.

Further documents, for example the manufacturer's declaration of incorporation, are also part of these installation instructions.

Structural features in the text

Defined structural features are assigned to the various elements within these installation instructions. A distinction can therefore be easily made between the following elements:

Normal text

- Lists

➤ Action steps.

- ① These tips contain additional information, such as special information on the simple installation of the device.

Copyright

These operating instructions contain information that is subject to copyright. Do not copy, print or adapt these operating instructions to film or reproduce, process, reproduce or disseminate them with any other method, whether in whole or in part, without prior written consent from TENTE-ROLLEN GmbH.

© 2021 TENTE-ROLLEN GmbH
All rights reserved.

Manufacturer's address

If you require further information, please contact the manufacturer:

TENTE-ROLLEN GmbH
Herrlinghausen 75
42929 Wermelskirchen, Germany
Phone: +49 (0) 21 96 / 99-0
Fax: +49 (0) 21 96 / 99-127
Email: info.de@tente.com
Web: www.tente.com

Information on the responsible sales partner can be found on the Internet at www.tente.com.

Safety

Intended use

The electric drive unit is used for the controlled movement of frames or hospital beds. It is only permitted to use it for commercial purposes indoors, on level and dry floors.

Proper use also includes observing and following all information in these instructions, particularly the safety information and technical data.

Any use of the unit beyond this is not considered proper use.

The following tasks in particular are not considered proper use:

- Use in areas with slopes or gradients
- Driveless shunting / pulling of the frame with the unit lowered (e.g. 'tugger train' travel with the unit lowered)
- Use of the unit in explosive atmospheres
- Private use
- Use outdoors on loose and unsurfaced ground, as well as moving over obstacles, e.g. edges or drain covers
- Use of the unit in conjunction with components that the manufacturer has not approved for use with this unit
- Use of the unit after conversions
- Use of the unit to lift or lower loads
- Dismantling the unit
- Use of the unit by unauthorised persons

Basic safety notices

Avoiding the risk of fatal injuries

- Fatal injuries from electric shock are possible if the device is connected incorrectly.
Only connect the drive unit according to the provided electrical connection diagram.

Avoiding the risk of serious injuries

- Risk of shear injury when lifting the drive castor between the fastening plate and unit housing.
Never put your hand between the fastening plate and unit housing.
- Risk of shear injury on the inner parts of the unit.
Never put your hand inside the unit, particularly if it is connected to the control.
- Risk of crush injury in the inner parts of the unit.
Never put your hand inside the unit, particularly if it is connected to the control.

- Risk of injury when moving the drive castor.
Never put your hand between the fastening plate and the unit housing during operation.
Install the unit only according to the drawings provided in these installation instructions.
Ensure that a danger symbol for crushing injuries is attached to the sides of the frame during installation.
The unit may only be operated if the danger symbols are easily recognisable.
- Risk of injury at rotating parts due to limbs being pulled in.
Never touch rotating parts. Wear close-fitting work clothing. Do not wear any loose jewellery. Cover long hair with a hair net.
- Fractures may occur if the emergency release is released by force.
Release the emergency release only in accordance with the information provided in these installation instructions.
- Severe injuries due to parts under spring tension when dismantling the unit.
Do not dismantle the unit under any circumstances.
- Risk of burns due to contact with a hot surface.
Excessive heat may build up on the unit during operation.
Avoid contact with the drive unit, particularly with the driving motor.

Avoiding the risk of slight injuries

- Cuts may be sustained on sharp edges on the device.
Wear protective gloves during all work on the device.
- Crushing is possible when actuating the emergency release.
Only actuate the emergency release according to the notices in these installation instructions. Wear sturdy protective gloves when testing the functioning of the emergency release.
- Crushing may be caused if the device collides with persons. During operation, ensure that no persons remain in the carriage's direction of travel.

Avoiding damage to property and malfunctions

- Damage to property is possible when an unsuitable control unit is used.
Only use control units that have been approved by the manufacturer for use with this device.
- Damage to property may be caused when the cable of the control unit is not fastened.
Ensure that the cable of the control unit is securely fastened to the carriage.
- A malfunction may be caused by the plug on the control unit becoming loose.
Secure the plug after connecting the device with two

hexagon socket head screws in the threaded holes intended for this purpose.

- A malfunction may be caused by insufficient fastening. Tighten the screws fastening the device with the specified torque.
- Damage and malfunctions may be caused by use outdoors. Soiling and wetness can affect functioning and lead to the device being damaged. Only use the device as intended.
- Damage may be caused by unsuitable cleaning agent. Only use cleaning agent that does not damage the construction material of the device. Please contact your sales partner for more information.

Qualifications of personnel

Installation may only be performed by specialist personnel. The specialist personnel must have knowledge and experience in the following areas:

- Installation of carriages, for example hospital beds
- Mounting additional electrical equipment onto carriages (specialist electricians)
- Creating connections for the types of equipment used
- All notices in these installation instructions and the included documents

Personal protective equipment

During all work on the device, ensure that protective clothing suitable to the respective task is worn. The protective clothing has to be chosen according to the risk that is expected for the task. The protective clothing must protect against the following risks in particular:

- Injuries to the body
- Hand injuries
- Injuries to the feet

Structural features of notices warning of danger



DANGER

Notices containing the word DANGER warn of a hazardous situation which may possibly lead to death or severe injuries.



WARNING

Notices containing the word WARNING warn of a hazardous situation which may possibly lead to death or severe injuries.



CAUTION

Notices containing the word CAUTION warn of a situation which may lead to slight or moderate injuries.

Structural features of notices warning of damage

ATTENTION!

These notices warn of a situation that leads to damage.

Description of the device

Scope of delivery and device overview

The device is supplied packaged and ready for installation.

The control system, current supply and mounting material are not included in the scope of delivery.

The figure below may differ slightly from the original.

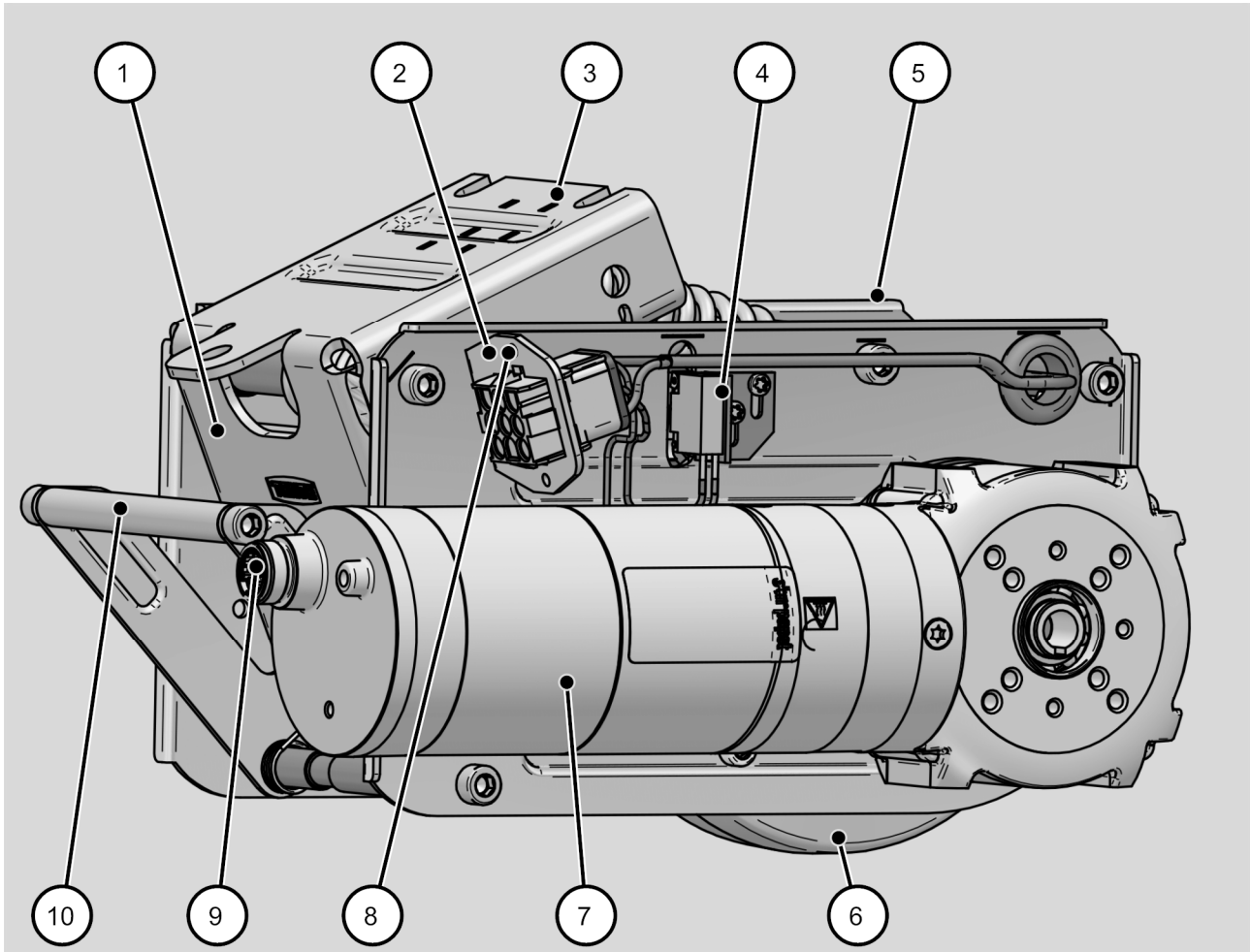

No.	Part
1	Rating plate (rear of the unit)
2	Connection socket for the servo motor and micro-switch
3	Fastening plate (optionally with M8×25 threaded bolts)
4	Micro-switch
5	Housing
6	Drive wheel
7	Driving motor
8	Threaded hole for securing the connector
9	Connector for the driving motor
10	Emergency release lever

Task and function

The unit is designed for the controlled movement of frames. It is installed under the frame and connected to a control and power supply suitable for the unit.

In the rest position / basic position, the drive wheel is raised to the top end position (see the following figure). If the control is actuated, the drive wheel lowers to the ground (see illustration on the right) and the travel drive is switched on.

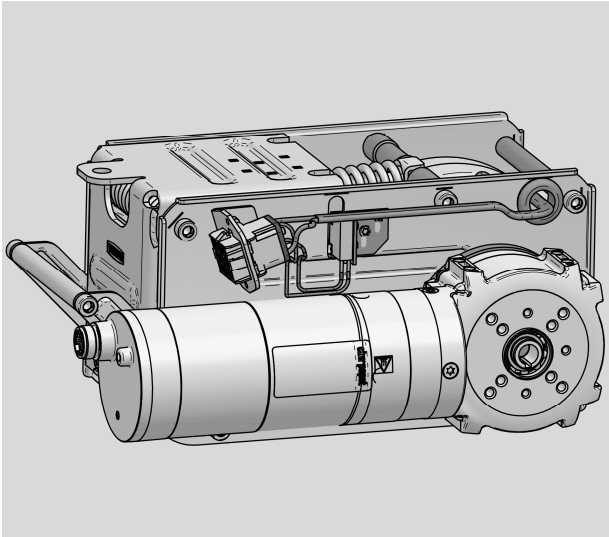

The unit can be used in 'Continuous driving' mode or optionally in 'Starting aid' mode.

The emergency release is used to raise the drive wheel in the event of a fault. If you switch on the control again after remedying the fault and press the drive switch for three seconds, the emergency release is cancelled. The drive wheel remains in the home position. Only the next time the travel drive is pressed will the unit be driven in normal mode again.

The micro-switch monitors the drive wheel's home position. You can move the micro-switch to adapt it to the control.

The device has a defined main direction of travel (see arrow).

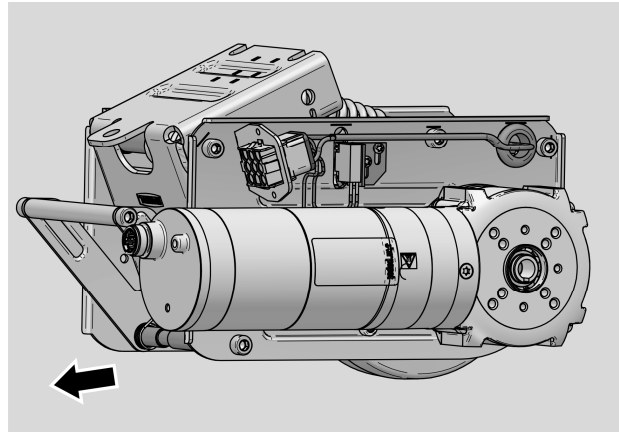

In the opposite direction, the device is only used for manoeuvring slowly.

- i Component replacements and repairs (except wheel and axle exchange) may only be carried out by the manufacturer.
 - Dismantle the unit from the frame in reverse order to installation.
 - Send the complete unit to your sales partner.
- i All of the described operating states, functions and behaviours refer to operation with the TENTE E-Drive ultimate control system.

Name plate

You will find the following information (at least) on the rating plate:

- Manufacturer's address
- Serial number
- Supply voltage
- Protection type

Assignment of the connection sockets

Connection socket type:

TYCO 350782-1, 09-pin. UMNL CAP HSG

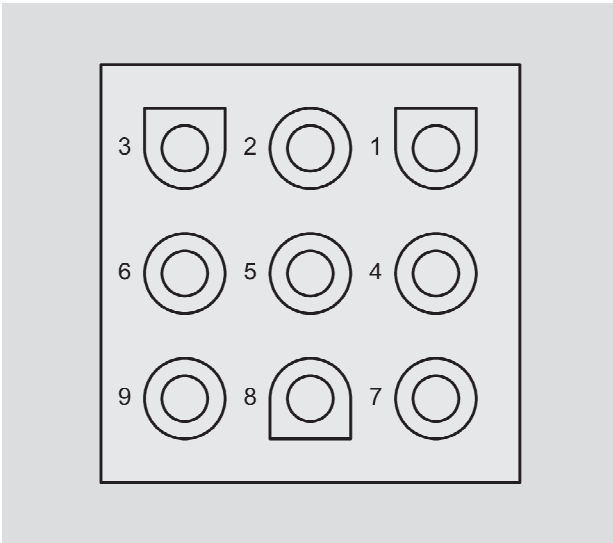

Pole	Component	Connection
1	Not in use	–
2	Position switch	Ground
3	Servo motor	Ground
4	Position switch	Max. 24 V DC, positive
5	Resistor	Max. 24 V DC, positive
6	Not in use	–
7	Servo motor	24 V DC, positive
8	Not in use	–
9	Not in use	–

Connector interface ECI-63.XX-K4
(socket on motor)

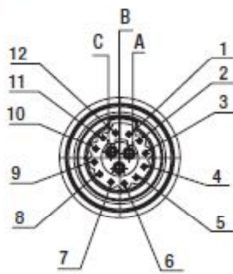

Wire interface ECI-63.XX-K4
(socket on motor)

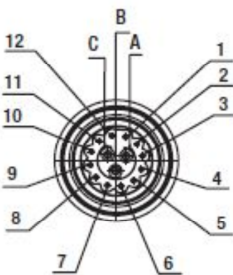

Cable connection VDC-3-49.15-K4
(mounted)

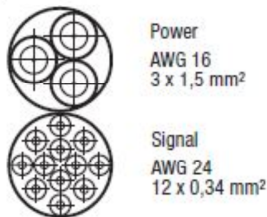

	Wire	Pin	Configuration	Function	AWG
Signal	white	1	IN A	NPN 24V	24
	brown	2	IN B	NPN 24V	
	green	3	IN 1	NPN 24V	
	yellow	4	IN 2	NPN 24V / analog 0...10V / brake	
	grey	5	OUT 1	PNP 24V	
	pink	6	OUT 2	PNP 24V	
	blue	7	OUT 3*	PNP 24V	
	red	8	Analog IN 1	0...10V (differential)	
	black	9	Analog GND	GND for analog IN 1 (differential)	
	violet	10	RS485 A (+)	Progr.-Bus	
	grey-pink	11	RS485 B (-)	Progr.-Bus	
	red-blue	12	U _{Logic}	Logic power supply + (24V)	
Power	grey	A	Ballast	Ballast resistor	16
	brown	B	U _{ZK}	Power supply	
	black	C	GND	Power- / Signal GND	

* Output (OUT 3) is only available on ECI-63.XX-K4

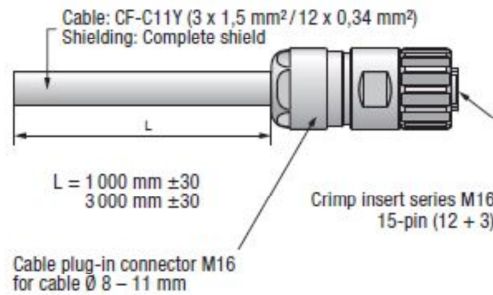

Technical data

Dimensions and weight	
Length	Max. 315 mm (emergency release pressed)
Width	178 mm
Height in home position	140 mm
Installation height	170 mm
Wheel diameter	125 mm, wear limit \varnothing 115 mm
Wheel width	35 mm
Wheel band	Rubber, non-marking
Weight	Approx. 6.5 kg

Characteristic values	
Maximum working load (weight of the frame being moved)	Dependent on the operating mode and traction resistance at the place of use (further information is available from your sales partner)
Maximum lifting force/contact pressure force	400 N
Maximum speed	4 km/h
Rated operating modes	S1: Continuous operation (as-delivered state) S4: Starting aid (optional)
Directions of movement	Forward and reverse
Ground clearance	30 mm
Maximum ground unevenness	± 15 mm
Emergency release	Mechanical
Constant lateral force when in contact with the ground	400 N
Protection type	IPX4 (splash water from all sides)
Permissible ambient temperatures	Operating temperature 5 to 40 °C humidity 90%, non-condensing
Permissible storage temperature	-20 to 50 °C

Sound audible acoustic energy IEC 60601-2-52, Section 201.9.6.2.1	
Switching	80 dB(A)
Driving	72 dB(A)

Transporting the device

Driving motor	
Rated voltage	24 V DC
Rated current	8.5 A
Rated power	178 W
Rated torque	8 Nm
Starting torque	25 Nm
Rated speed (motor)	4,000 rpm
Rated speed (gearbox output shaft)	196.75 rpm

Actuator	
Nominal voltage	24 V DC
Nominal current	3.5 A
Nominal output	14.8 W
Nominal torque	4 N m
Nominal speed	35.3 min ⁻¹

We reserve the right to implement technical changes.

- i The device consists of different metal types and electronic components.
 - Contact your sales partner for more detailed information on the construction materials used.

Transporting the device

- Transport the device in the original packaging.
- If the original packaging is not available, package the device so that it is protected against moisture and mechanical damage.

Preparing installation

Creating the prerequisites for installation

- Ensure that the carriage onto which the device should be installed fulfils the following prerequisites:
 - You must have adjusted the frame rollers' tread and rolling resistance to the mass to be moved. If you have any questions, please contact your sales partner.
 - An interface with corresponding threaded holes or through holes must be provided on the frame.
 - The interface must be designed in such a way that the drive-related forces to be expected during operation can be safely transmitted. The design must also take the unit's lifting force into account. Your sales partner will support you with the design.
 - The distance between the floor and the interface must be 170 mm.
 - The interface must be installed so that the unit's main direction of travel is the same as the driven frame's main direction of travel.

When used as a drive for hospital beds and medical equipment, the following requirements must also be met:

- The requirements set down in IEC 60601-52 are met
- At least four hospital bed rollers with the 'full lock' function are available
- The roller system has a central locking system.
- All applicable laws, standards and guidelines are observed and followed.

The control unit, which is not included in the scope of delivery, has to be approved for use by the manufacturer.

- Please contact the manufacturer if you wish to use a control unit that is not supplied or approved by the manufacturer.

Mounting the interface

The position of the interface differs depending on the intended purpose. It can be mounted both centrally between the frame castors and off-centre. However, central positioning is the best in all cases.

- Contact your sales partner if you have any questions about the interface position.
- Ensure that the following preparations have been taken at the interface:
 - The interface must fulfil the prerequisites mentioned in the previous section.
 - The interface must have three holes of 9 mm diameter or three M8 threaded holes in order to fasten the device. The screw-in depth must be at least 10 mm. The arrangement of the fastening holes depends on the main direction of travel (see arrow).

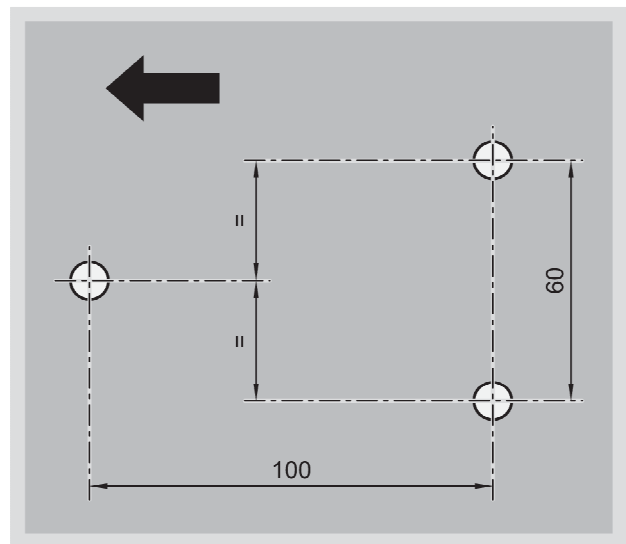

Fitting an interface on a frame

i This method applies only when one unit is used.

The interface on the frame must be arranged so that the drive wheel (1) of the unit is aligned parallel to the existing castors (2). The following points must be observed when arranging the drive wheel:

- If it is arranged off-centre and the weight is distributed unevenly on the frame, the frame can be raised on one side when the drive wheel is extended. Consult your sales partner in this situation.
- The further the drive wheel is installed on the outside of the frame, the greater the risk of crushing when the drive wheel is raised or lowered.

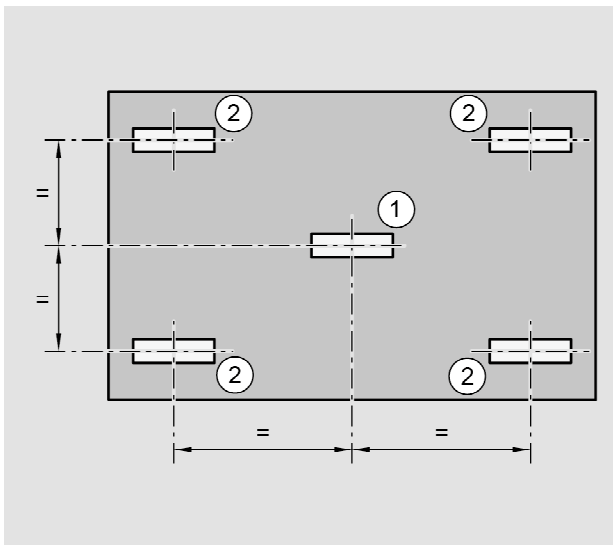

No.	Description
1	Drive wheel
2	Steering castors

➤ Fasten the interface to the desired position.

i If the installation position is different or if other castors are used, contact your sales partner.

Unpacking the device



CAUTION

Cuts may be sustained on sharp edges on the device.

➤ Wear protective gloves during all work on the device.

- Take the device out of the packaging.
- Check the device for transport damage.
- Contact your sales partner if you discover transport damage.

Installing the device

To install the device on the prepared carriage, you will require the following:

- This device (drive unit)
- Torque wrench with a setting range to 20 N m
- Three M8 screws of minimum strength class 8.8 (DIN EN 24017). Select the length of the screws according to type of fastening (threaded holes or through holes in the interface)
- If fastening with through holes, three M8 nuts of strength class 8
- The corresponding tool depending on the fastening type

Fastening the device



CAUTION

Cuts may be sustained on sharp edges on the device.

- Wear protective gloves during all work on the device.

In order to fasten the device to the carriage, proceed as follows:

- Turn the two screws (2) slightly into the threaded holes of the interface.

Or

- Attach the two screws (2) slightly with the nuts to the interface.
- Push the device with the open holes of the fastening plate (3) over the two pre-mounted screws.
- Insert the third screw through the hole (1) of the fastening plate and attach this to the interface.
- Tighten the three screws with a torque of 20 N m.

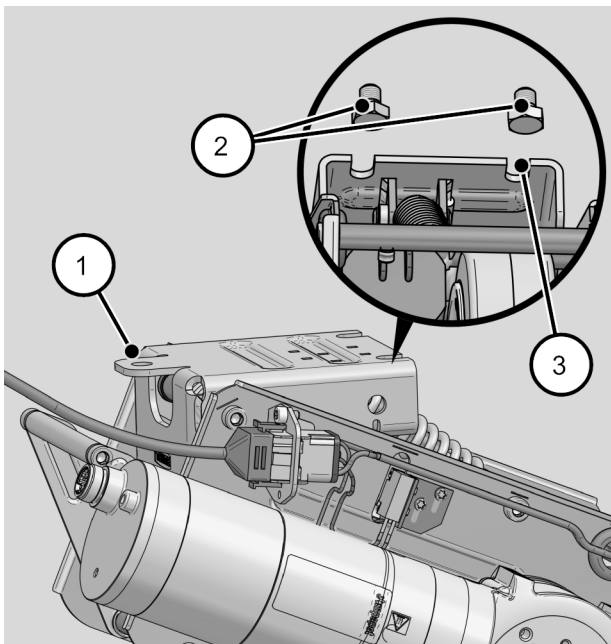

Proceed as follows if you are using a unit with stay bolts:

- Guide the unit's stay bolts through the corresponding drilled holes in the interface.
- Secure the unit to the interface using three nuts.
- Tighten the nuts with a torque of 20 Nm.

Connecting the device



DANGER

Danger of death due to electric shock if the unit is incorrectly connected.

- Connect the unit only in accordance with the electrical wiring diagram on page 8.

ATTENTION!

Material damage or malfunctions on the device due to incorrect assignment of the connections.

- Make sure that the assignment of the control system and device connections correspond.

Proceed as follows to connect to the control:

- Remove the M4 x 6 cylinder screw (1).
- Insert the control's connector into the unit's connection socket until it clicks into place.
- Secure the connector's position with the M4 x 6 cylinder screw (1).
- Tighten the cylinder screw (1) so that it is hand-tight.

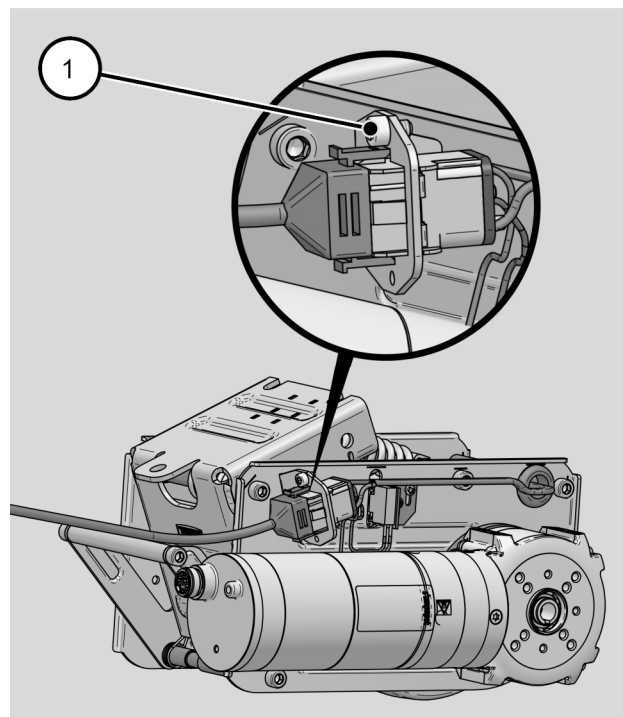

Commissioning the device and testing its functioning

Commissioning the device



WARNING

Risk of shearing between fastening plate and device housing when lifting the drive roll.

- Never reach between the fastening plate and the device housing.

The further out on the carriage the drive wheel is mounted, the greater the danger of crushing when lifting and lowering the drive wheel.



WARNING

Risk of shear injury on the inner parts of the unit.

- Never put your hand inside the unit if it is connected to the control.

- During operation with hospital beds or medical equipment, ensure that all applicable laws, standards and guidelines are observed and followed.

ATTENTION!

When the arrangement is offset from the centre and there is unequal weight distribution on the carriage, then the carriage can be lifted on one side when the drive wheel is lowering.

- Ensure that the carriage is evenly loaded.



WARNING

Risk of burns due to contact with a hot surface.

Excessive heat may build up on the unit during operation.

- Avoid contact with the drive unit, particularly with the driving motor.

- Use the unit as described in the operating instructions for the connected control.

Setting the micro switch

By setting the micro-switch, you can adapt the unit to various controls. For adjustment, you need a screwdriver that matches the screw type.

The micro-switch switches off the servo-motor for lifting the drive wheel. By moving the micro-switch (2), you can adjust how high the drive wheel is raised:

- To raise the drive wheel higher, push the micro-switch down.
- To raise the drive wheel less, push the micro-switch up.

The manufacturer recommends setting the micro-switch so that the top edges of the housing (3) are parallel to the interface (1) in the basic position.

If the micro-switch is not switched during raising, the unit will lower and raise again. An error message is then issued via the TENTE control. The position of the micro-switch must then be reset by pushing it up further.

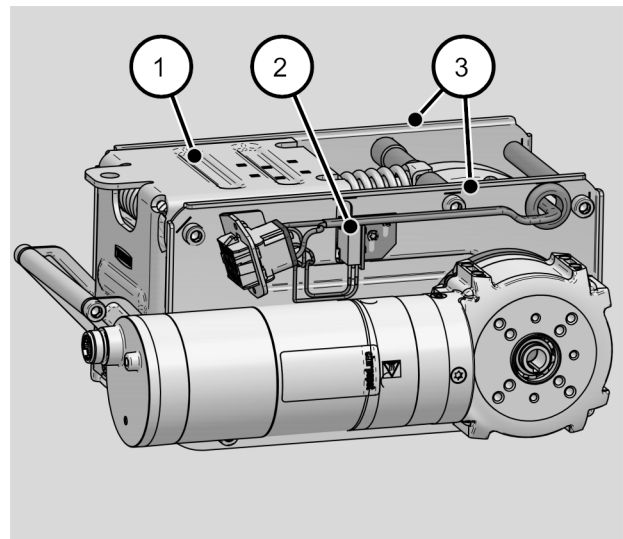



WARNING

Risk of crushing by the interior parts of the device.

- Never reach inside the device when it is connected to the control unit.
- Remove the connection plug of the control unit before working on the device.

ATTENTION!

Incorrect setting of the micro switch causes malfunctions when resetting the emergency release.

- Ensure the correct setting of the micro switch.
- Set the micro switch as described in the following section.

- If you have any queries contact your sales partner.
- Ensure that the device is disconnected from the power supply.
- Release the two screws (2).
- Push the micro switch (1) to the desired position.
- Tighten the two screws (2) by hand.
- Connect the device to the power supply.
- Check if the drive wheel is lifted into the basic position.
- Repeat the setting if the drive wheel is not lifted as desired.

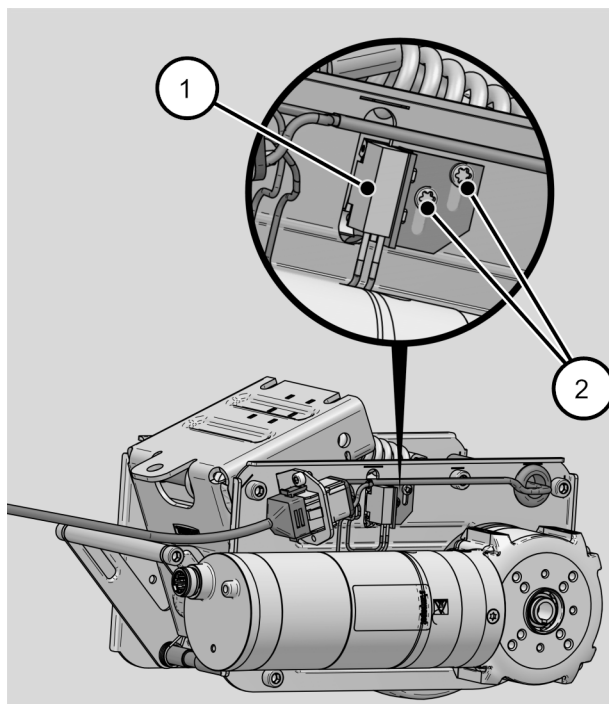

Testing the functioning of the emergency release

Test the functioning of the emergency release after commissioning.

During this test the device has to be in the same position as during operation.

- Switch off the control unit.



CAUTION

Risk of crushing when actuating the emergency release.

- Ensure that no body parts can become caught between lever and device housing or carriage when actuating the emergency release.
- Wear protective gloves when actuating the emergency release.

- To operate the emergency release and raise the drive wheel, pull the lever down firmly until you feel the lever engage.

The drive is not completely raised to the home position. The lever remains locked in the bottom position.

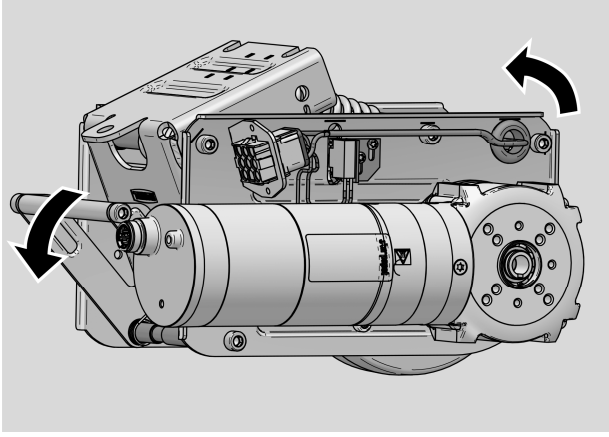

WARNING

Risk of bones being broken or crushing injuries when releasing the latched-in lever by force.

- Only release the lever as described here.

- Switch on the control.
 - Press the drive switch for three seconds.
- The emergency release is cancelled. The drive wheel moves to the home position.
- Press the drive switch again.
- The drive wheel is lowered in normal mode. Proceed as follows if this does not happen:
- Switch off the control.
 - Make sure that the control is connected correctly and working properly.
 - Make sure that the micro-switch is in the correct position.
 - Repeat the function test.
 - Contact your sales partner if the device is not functioning properly.

Maintaining the unit

To ensure safe and efficient operation and to prevent damage, you must lubricate the following points at intervals of 5,000 cycles (lowering and lifting). Use spray oil or spray grease for this.

This figure shows a similar unit.

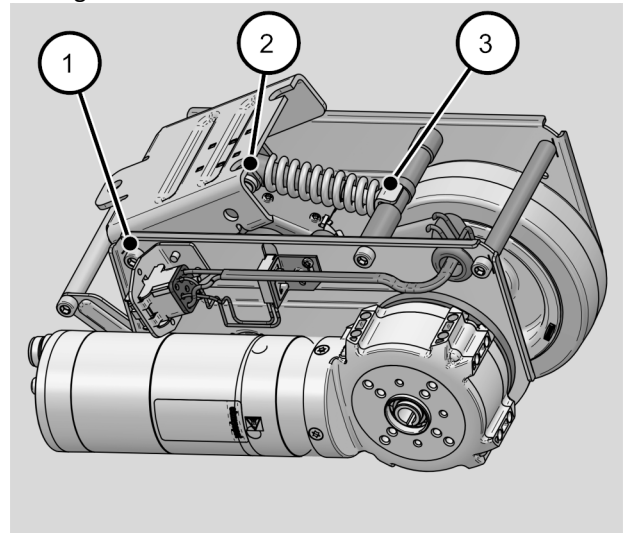

No.	Part
1	Bearing position (both sides)
2	Bearing position, guide sleeve
3	Bearing position, guide pins