

PRODUCT INFORMATION

E-DRIVE

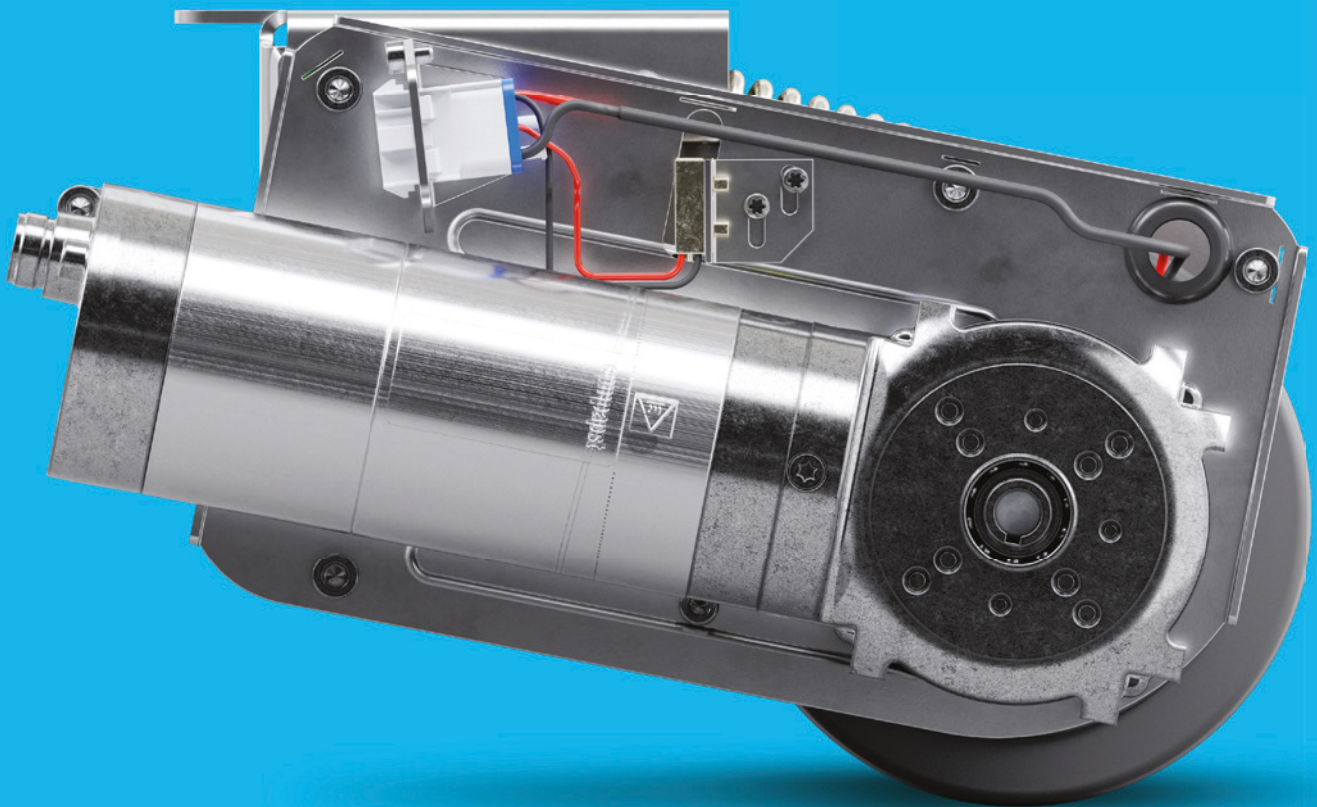

TENTE

BETTER MOBILITY. BETTER LIFE.

E-DRIVE

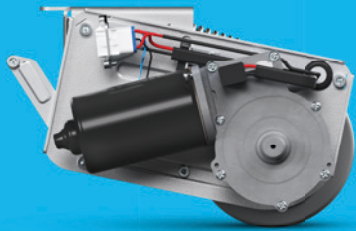

BASIC E-DRIVE FLEX

PAGES: 8-11



ADVANCED E-DRIVE OPTIMA

PAGES: 12-15

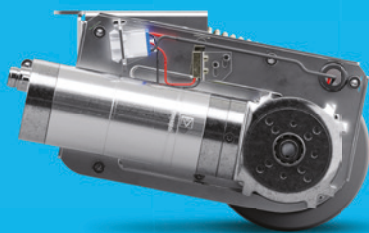

SUPERIOR E-DRIVE ULTIMATE

PAGES: 16-19



COMPONENTS

PAGES: 20-25

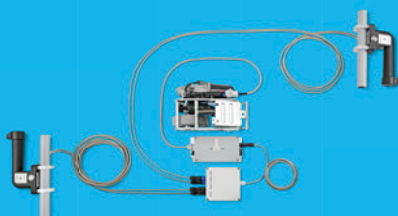

SET-UP

PAGES: 26-28

BETTER MOBILITY IN PREMIUM QUALITY

TENTE stands for smart mobility solutions which noticeably improve people's lives and their work environment. TENTE solutions increase productivity, ensure safety and open up new horizons in matters of design, durability as well as environmental friendliness. Our high production values can be relied on by leading manufacturers and companies from different industries.

This guide will provide all of the technical information you need to get an understanding of our E-Drive systems. It will also demonstrate the value that this system could add to your organisation. Among others:

Improved Ergonomics

The ergonomic system helps to prevent ailments to the neck, back, shoulders and hands among users – especially in times of high demographic change. Your investment in E-Drive will quickly pay off through fewer illness-related absences.

Improved Ergonomics

E-Drive helps to make design operational procedures more efficient and, as a result, to realise cost savings.

High Flexibility

Thanks to the lifting motor, E-Drive can be switched on as required and has no ground contact when in standby position. The practical system also makes it easy to be integrated into existing transport devices.



FEATURES



Flexible use

The lifting motor makes it easy to turn the device on and off as required. No ground contact in standby position.

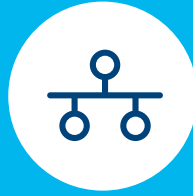

Practical system solution

Due to its extremely compact design, the system solution can be easily integrated into existing transport devices.



Accelerated processes

Faster start-up with heavy loads to accelerate operating processes.



Ergonomic operation

Ergonomically designed hand control unit with system and battery status LED display. One-button operation.



Optimal ground contact

High contact force between the wheel and the floor with a compensation function for uneven floors.



User-friendly assembly

Hand-held control unit can be attached flexibly in a vertical or horizontal position.



Reliable electronics

Infinitely variable speed regulation (forwards and backwards) through safety-tested drive switches.



Optimised steering mechanism

Fifth wheel allows for improved steering in both curved and straight line paths over long distances.



Quiet operation

Soft wheel version for a quiet working environment.

E-DRIVE PRODUCT OVERVIEW

We offer three types of E-Drive systems: E-Drive flex, E-Drive optima and E-Drive ultimate.

E-Drive flex

Electric drive unit

Our basic version offers you the possibility to move loads effortlessly without any force.

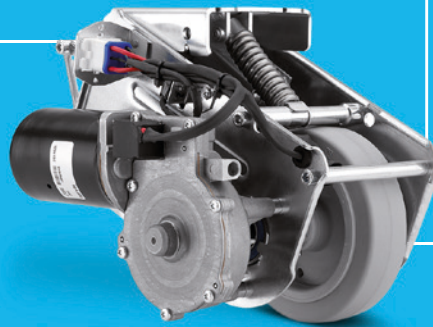

Individually adjustable
Easy setting of adjustable parameters via USB interface.

Tested quality
Tested according to European standard in our own test laboratory.

E-Drive optima

Brushless motor

Brake assist and constant torque regardless of speed and load.

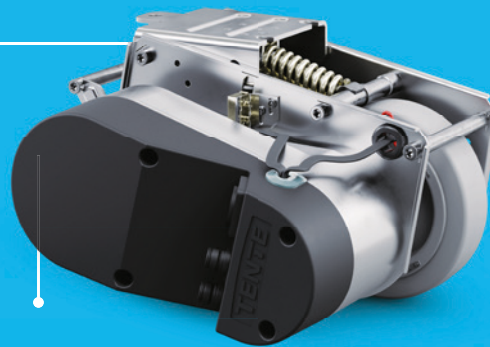

Optimum power
E-Drive optima helps to get up and down slopes safely thanks to a powerful motor.

Adjustable speed

From 1 to 6 km/h depending on your application and need. Forward and backward can be set differently.

E-Drive ultimate

Maximum motor power

Immediately available thanks to brushless motor with constant torque regardless of speed.

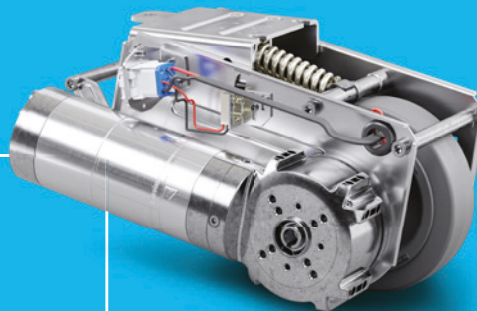

Fast slowdown
Intuitive and safe speed reduction by the user.

Flexible control

Programmable logic controller (PLC) enables application-specific adaptations.

MOUNTING E-DRIVE

The E-Drive works like a fifth wheel and offers perfect directional stability, especially when using four castors. The system is activated via the hand control unit. Once the drive unit is lowered, it is ready for use. The stepless speed regulation (forward and backward) enables an optimal use. The required energy is supplied by a powerful, rechargeable battery. In the lifted position, it can be flexibly moved crosswise in confined spaces. There are different ways to position the E-Drive under your application. But, no matter which position you choose, E-Drive assures high directional stability.

Mounting position for applications with four swivel castors

When using a trolley with four swivel castors, E-Drive is best placed in the middle of the trolley between the front and rear axles.

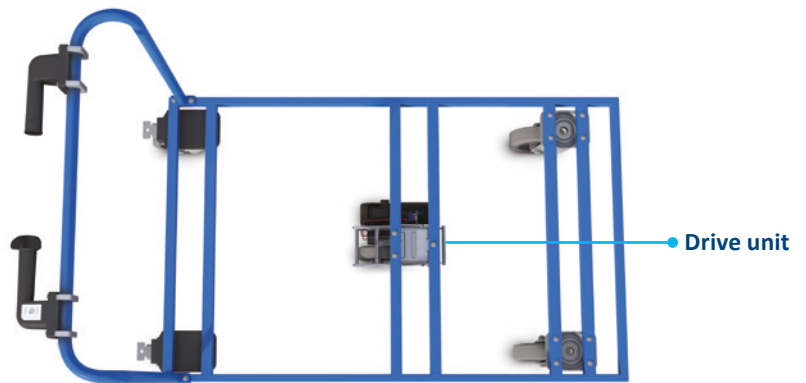

Mounting position for applications with two swivel and two fixed castors

When using a trolley with two swivel and two fixed castors, E-Drive is best placed between the two fixed castors.

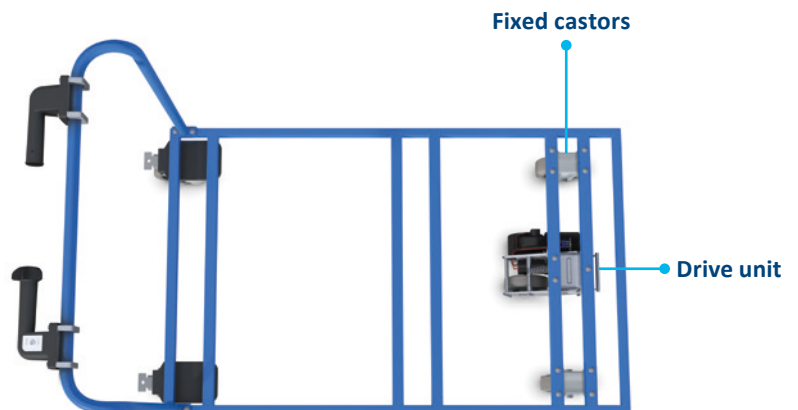

Application example of E-Drive
Foldable transport trolley with all E-Drive flex components.

FACTS ABOUT THE DIFFERENT E-DRIVE SYSTEMS

Version	E-Drive flex	E-Drive optima	E-Drive ultimate
Load to move* (single set-up)	Up to 600 kg	Up to 800 kg	Up to 800 kg
Load to move* (twin set-up)	Up to 1200 kg	Up to 1600 kg	Up to 1600 kg
Ramps drive (slopes up to 5%)	No	Yes	No
Twin operation mode	Yes	Yes	Yes
Gearbox material	Synthetics	Sprockets and belts	Metal
Actuator	Brushed motor	Brushless motor	Brushless motor
Recuperation	No	No	No
Slowdown function	No	Yes	Yes
Emergency stop	No	No	Yes
Constant torque	No	Yes	Yes
Certifications	Yes	Yes	Yes
Customising (on demand)	No	Limited	Yes

* Reference value may deviate due to soil and other environmental factors.
Directive 2006/42/EC must be observed by the user.

E-DRIVE FLEX

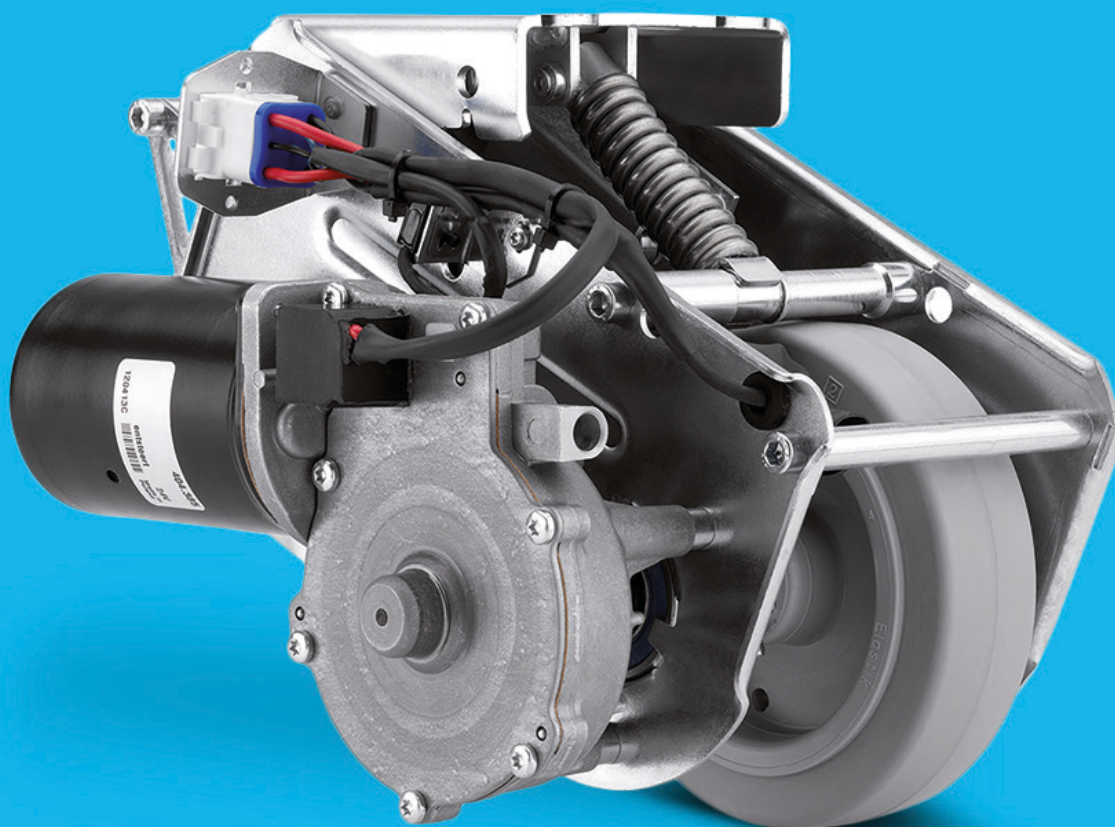

BASIC SOLUTION FOR STANDARD APPLICATIONS

Drive unit E-Drive flex

E-Drive flex is ideal as an entry-level model if you want to update your logistics processes to increase your productivity and ergonomics. This starter kit can move up to 600 kg* in a single set-up and up to 1200 kg* with a twin set-up. The flex model features all basic accessories you need for your transition to motorised drive power.



STANDARD HANDLE

Standard on and off button and indication if battery is empty. Also shows the current drive mode.



ADJUSTABLE SPEED

The force applied to the thumbwheel controls the speed in forward and backward directions.

* Reference value may deviate due to soil and other environmental factors.
Directive 2006/42/EC must be observed by the user.

E-DRIVE FLEX

Motorised castors with electric drive

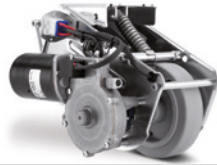

Description	i Article description	EDFAUFF125P60
	Length	Max. 315 mm (emergency release actuated)
	Width	190 mm
	Height in home position	140 mm
	Installation height	170 mm
	Wheel diameter	125 mm, wear limit \varnothing 115 mm
	Wheel width	35 mm
	Wheel tread	Solid rubber, non-marking, Shore A 63
	Weight	Approx. 6 kg
	Max. thrust force	25 daN
	Max. lifting force / contact pressure force	400 N
	Max. speed	Approx. 4 km/h
	Directions of travel	Forwards and backwards
	Ground clearance	30 mm
	Max. ground unevenness	± 15 mm
	Emergency release	Mechanical
	Max. lateral force when in contact with the floor	400 N
	Protection type	IPX4 (splash water from all sides, all plugs plugged in)
	Permissible ambient temperature	Operating temperature 5 °C to 40 °C, air humidity 90 %, non-condensing
Permissible storage temperature	-10 °C to 45 °C	

Drive unit travel motor

Description	i Nominal voltage	24 V DC
	Nominal current	7,0 A
	Nominal output	73,1 W
	Nominal torque	4 Nm
	Nominal speed	174,5 min ⁻¹

Drive unit actuator

Description	i Nominal voltage	24 V DC
	Nominal current	3,5 A
	Nominal output	14,8 W
	Nominal torque	4 Nm
	Nominal speed	35,3 min ⁻¹

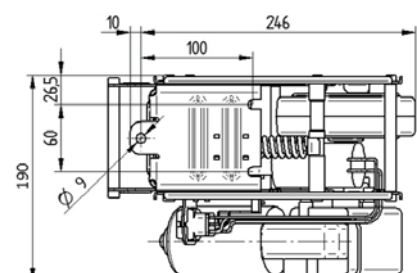
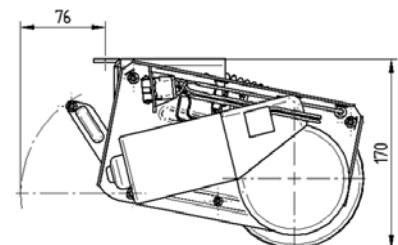
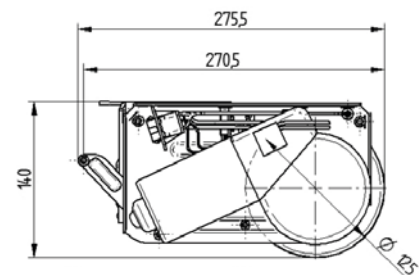

E-DRIVE FLEX COMPONENTS

Single Set-Up

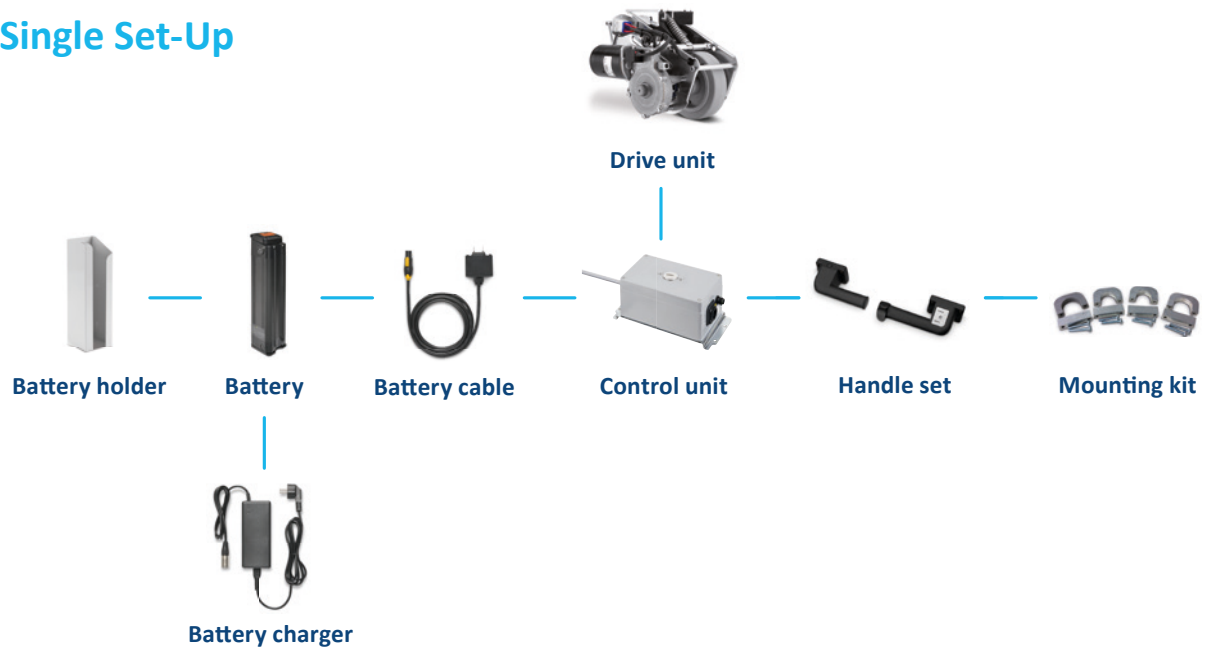

Twin Set-Up

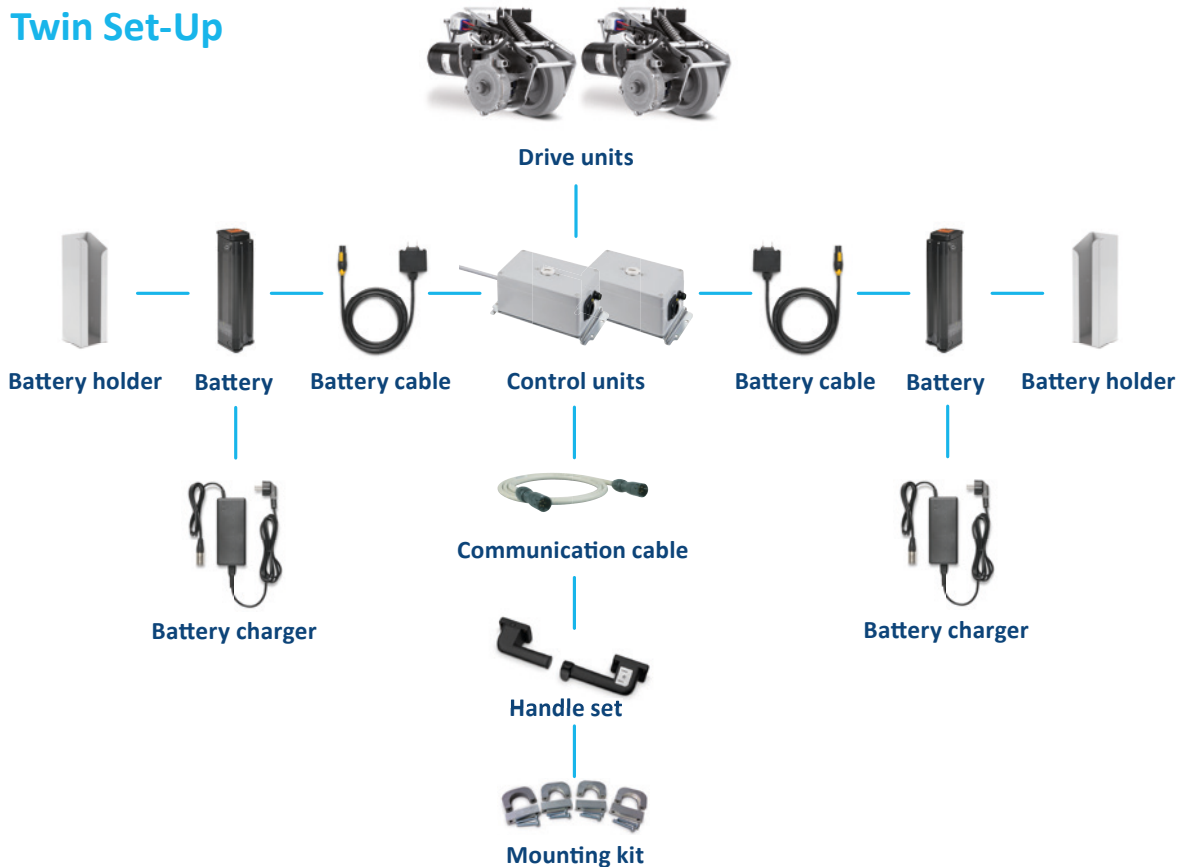

Simplified representation of the interdependencies. A detailed description can be found in the E-Drive assembly instructions, which is available on request.

E-DRIVE OPTIMA

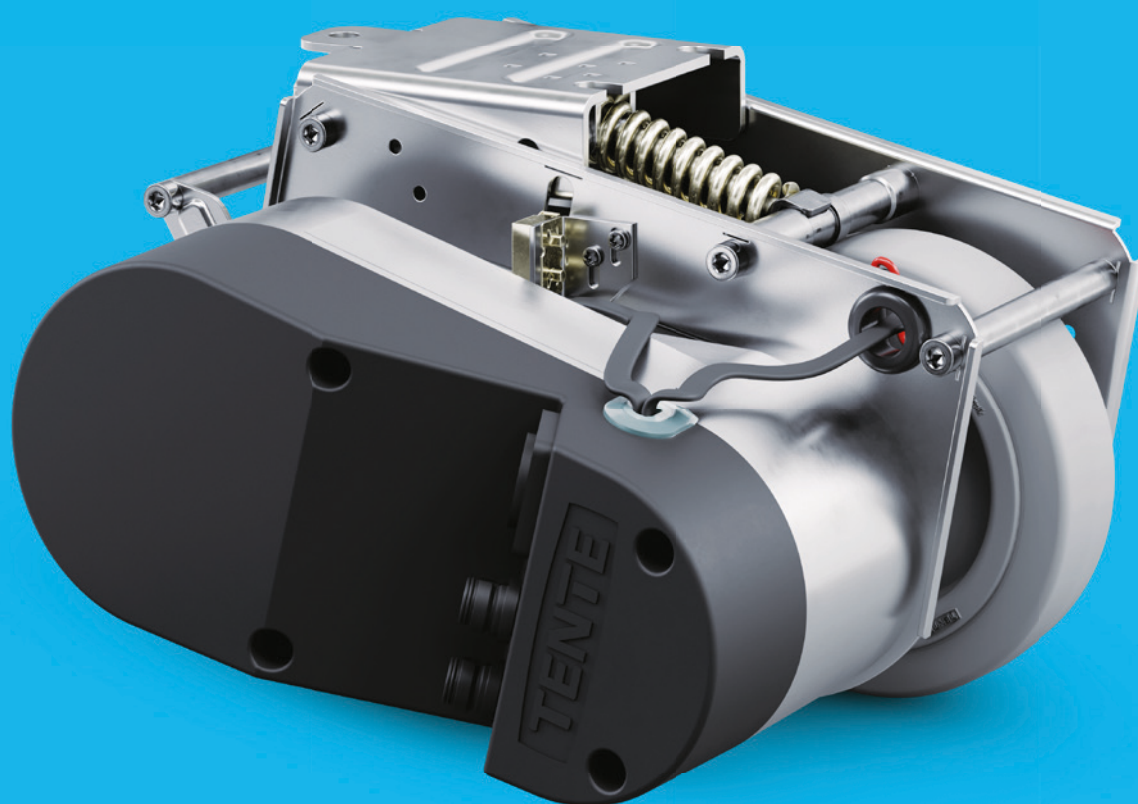

ADVANCED SOLUTION FOR STANDARD APPLICATIONS WITH A HIGHER SAFETY DEMAND

Drive unit E-Drive optima

E-Drive optima is suitable for demanding applications that require additional safety. This is mainly due to the deceleration function when the handle is released. Another advantage this drive unit offers is its compact space-saving concept. Control and drive unit of optima are not two different units but one combined module, which makes installation much easier for you. The compact E-Drive optima model can move up to 800 kg* in a single set-up and up to 1600 kg* with a twin set-up.



ASSISTED STOP BUTTON

When the operator presses the assisted stop button (red) on the handle, E-Drive optima decelerates to a standstill and then lifts up. This feature ensures the safety of the users.



ADJUSTABLE SPEED AND SLOWDOWN ASSIST

The force applied to the thumbwheel controls the speed in forward and backward directions. In the neutral position, the system decelerates to help the operator stop the trolley.

* Reference value may deviate due to soil and other environmental factors.
Directive 2006/42/EC must be observed by the user.

E-DRIVE OPTIMA

Motorised castors with electric drive and integrated control unit



Description	i Article description	EDOAUFF125P60
	Length	Max. 315 mm (emergency release actuated)
	Width	222 mm
	Height in home position	140 mm
	Installation height (optimum)	170 mm
	Wheel diameter	125 mm, wear limit \varnothing 115 mm
	Wheel width	35 mm
	Wheel tread	Solid rubber, non-marking, Shore A 63
	Weight	7,25 kg
	Maximum thrust force	32 daN
	Max. lifting force / contact pressure force	400 N
	Maximum speed	6 km/h
	Directions of travel	Forwards and backwards
	Ground clearance	30 mm
	Maximum ground unevenness	± 15 mm
	Emergency release	Mechanical
	Protection type	IPX4 (splash water from all sides, all plugs plugged in)
	Permissible ambient conditions	Operating temperature 5 °C to 40 °C, air humidity 90 %, non-condensing
	Permissible storage temperature	-20 °C to 50 °C

Drive unit travel motor

Description	i Nominal voltage	18 V DC
	Nominal current	12,1 A
	Nominal output	181 W
	Norminal torque	9 Nm
	Nominal speed	198,9 min ⁻¹

Drive unit actuator

Description	i Nominal voltage	24 V DC
	Nominal current	3,5 A
	Nominal output	14,8 W
	Norminal torque	4 Nm
	Nominal speed	35,3 min ⁻¹

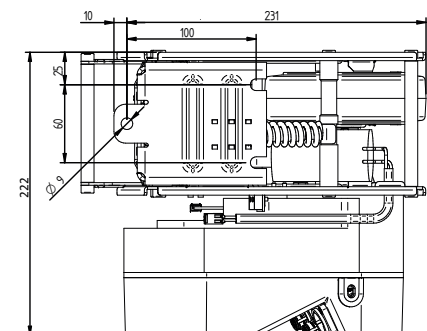
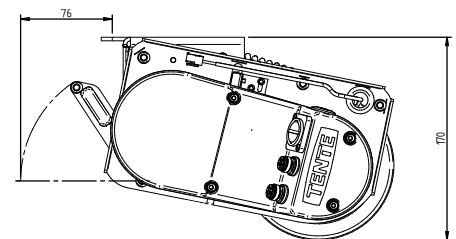
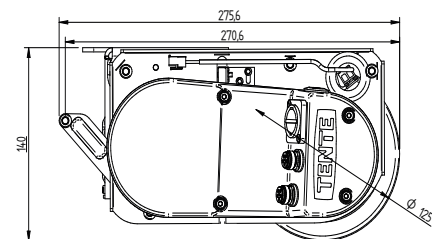

E-DRIVE OPTIMA COMPONENTS

Single Set-Up

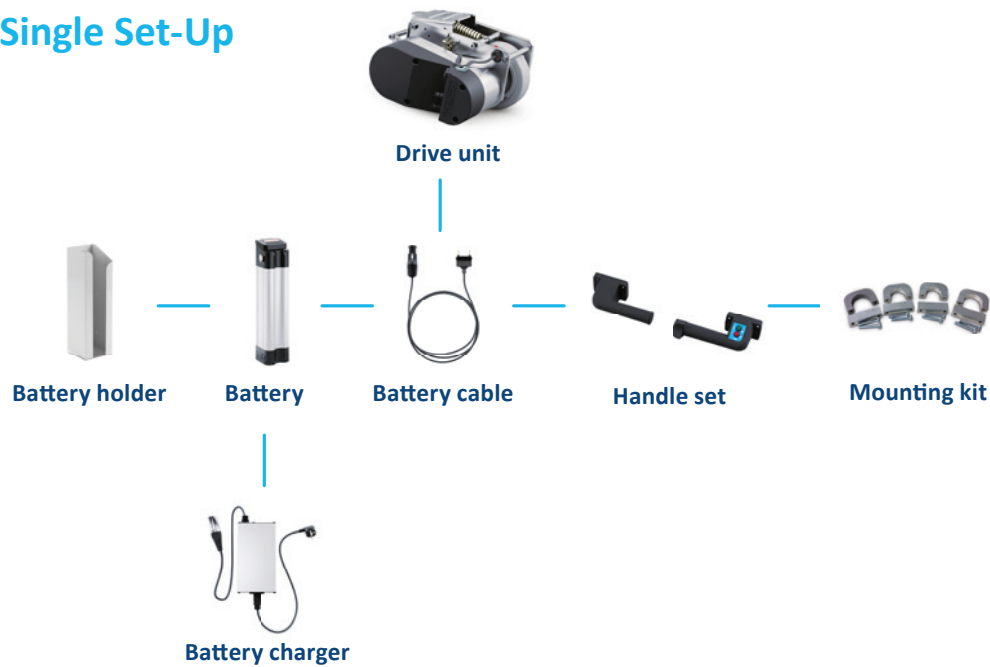

Twin Set-Up

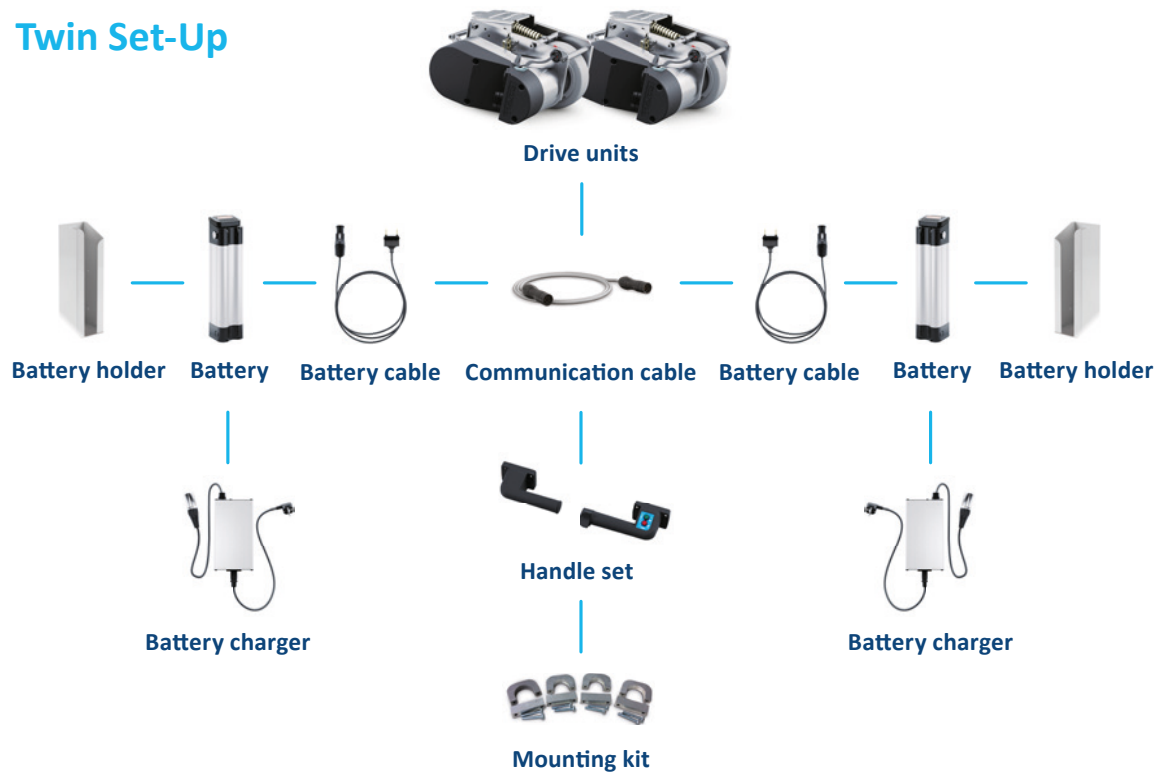

Simplified representation of the interdependencies. A detailed description can be found in the E-Drive assembly instructions, which is available on request.

E-DRIVE ULTIMATE

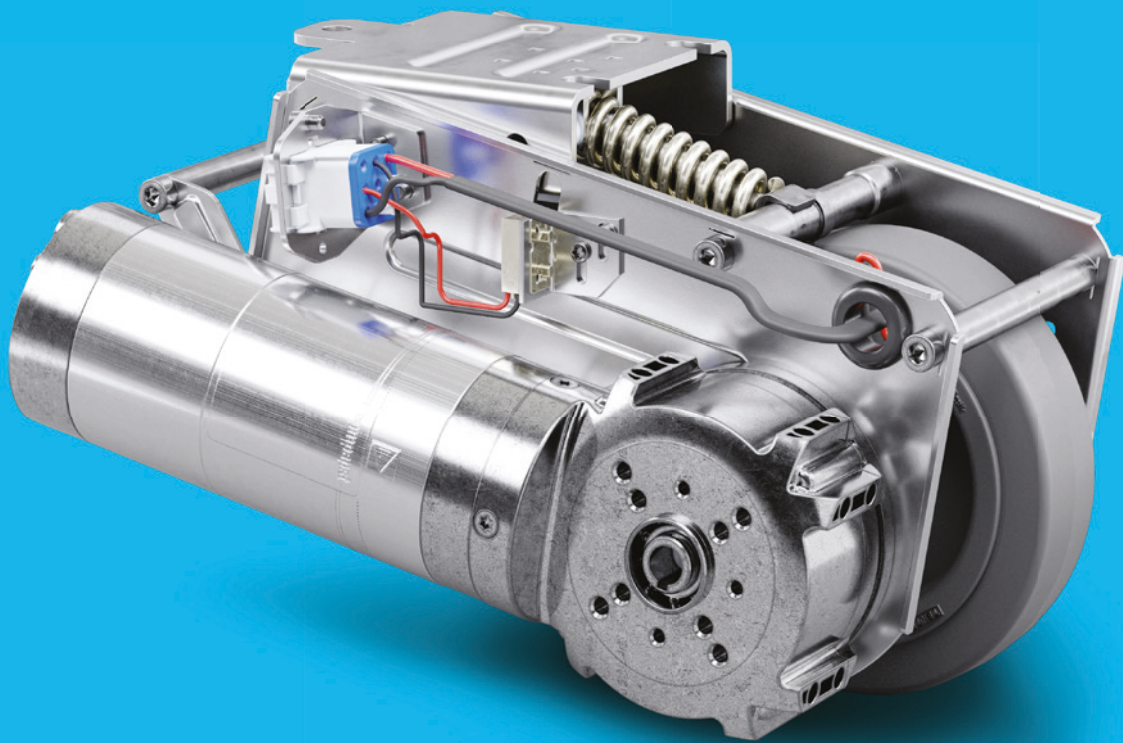

SUPERIOR SOLUTION FOR APPLICATIONS WITH A HIGHER CUSTOMISATION DEMAND

Drive unit E-Drive ultimate

E-Drive ultimate is all about customisation thanks to its flexibility. Due to its programmable logic controller, the drive unit can be equipped with additional components. These can be, for example, lights or sound signals all around. The drive unit with its robust and hardened gear drive can move up to 800 kg* in a single set-up and up to 1600 kg* with a twin set-up. Please feel free to contact us for further customisations of E-Drive ultimate.



EMERGENCY BUTTON

When the operator presses the emergency button (red) on the handle, all power will be cut off.



ADJUSTABLE SPEED AND SLOWDOWN ASSIST

The force applied to the thumbwheel controls the speed in forward and backward directions. In the neutral position, the system decelerates to help the operator stop the trolley.

* Reference value may deviate due to soil and other environmental factors.
Directive 2006/42/EC must be observed by the user.

E-DRIVE ULTIMATE

Motorised castors with electric drive

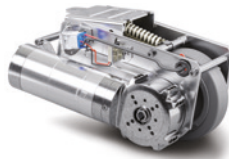

Description	i Article description	EDUAUFF125P60 24V
	Length	Max. 315 mm (emergency release actuated)
	Width	178 mm
	Height in home position	140 mm
	Installation height	170 mm
	Wheel diameter	125 mm, wear limit \varnothing 115 mm
	Wheel width	35 mm
	Wheel tread	Solid rubber, non-marking, Shore A 63
	Weight	Approx. 8 kg
	Maximum thrust force	32 daN
	Max. lifting force / contact pressure force	400 N
	Maximum speed	Approx. 4 km/h
	Directions of travel	Forwards and backwards
	Ground clearance	30 mm
	Maximum ground unevenness	± 15 mm
	Emergency release	Mechanical
	Maximum lateral force when in contact with the floor	400 N
	Protection type	IPX4 (splash water from all sides, all plugs plugged in)
Permissible ambient conditions	Operating temperature 5 °C to 40 °C, air humidity 90 %, non-condensing	
Permissible storage temperature	-10 °C to 45 °C	

Drive unit travel motor

Description	i Nominal voltage	24 V DC
	Nominal current	8,5 A
	Nominal output	144 W
	Nominal torque	7 Nm
	Nominal speed	197 min ⁻¹

Drive unit actuator

Description	i Nominal voltage	24 V DC
	Nominal current	3,5 A
	Nominal output	14,8 W
	Nominal torque	4 Nm
	Nominal speed	35,3 min ⁻¹

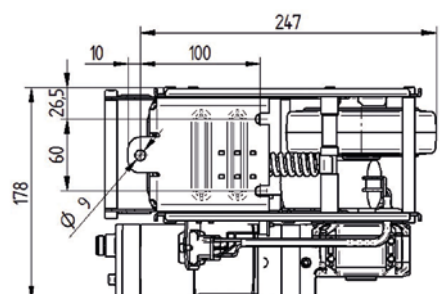
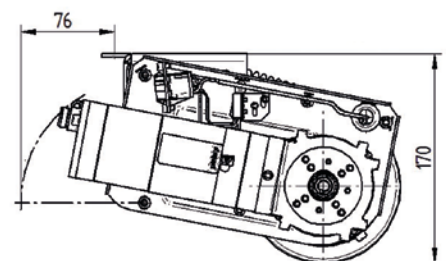
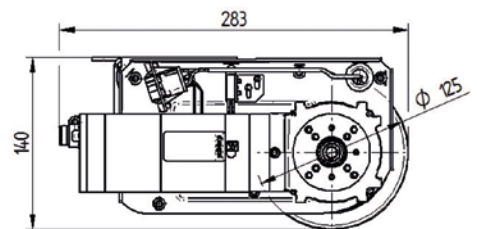

E-DRIVE ULTIMATE COMPONENTS

Single Set-Up

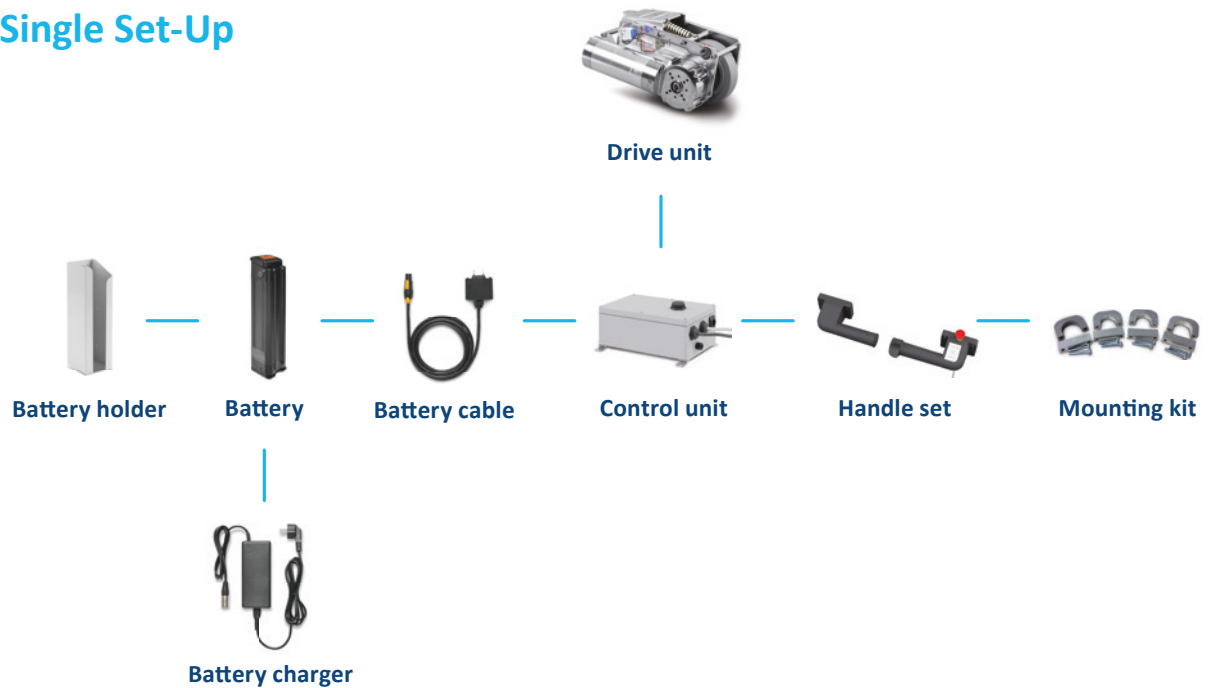

Twin Set-Up

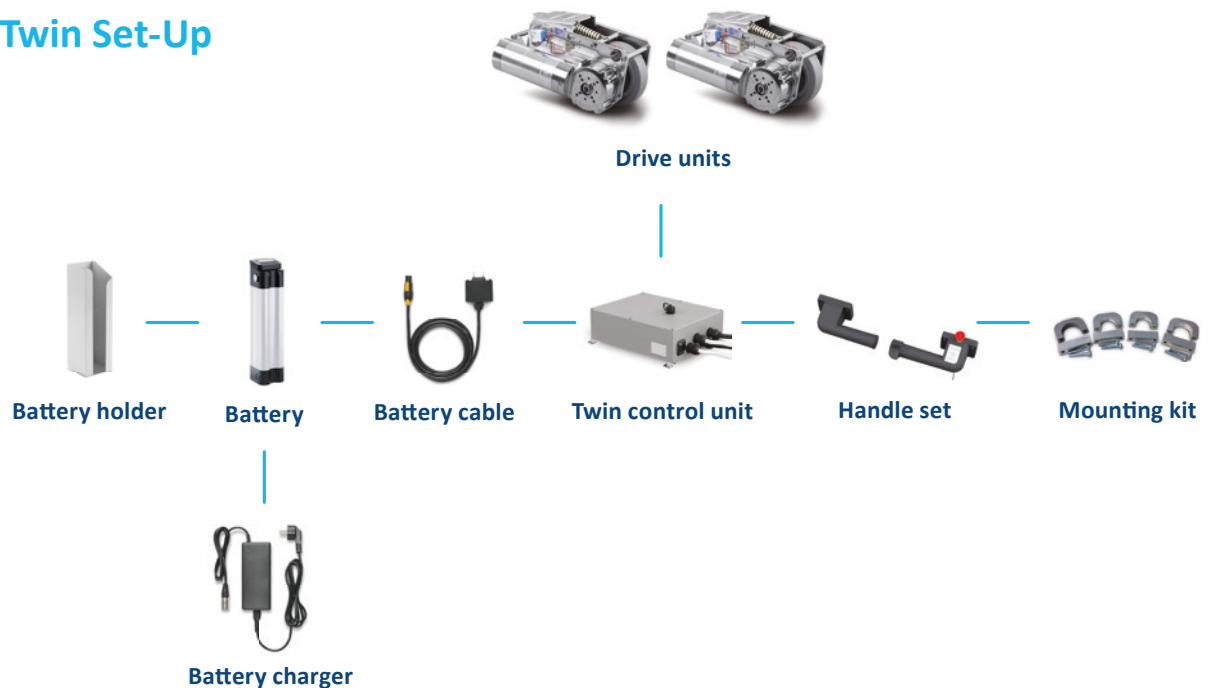

Simplified representation of the interdependencies. A detailed description can be found in the E-Drive assembly instructions, which is available on request.

E-DRIVE COMPONENTS





Control unit

Description	Compatible with	E-Drive flex	E-Drive ultimate
	Article description	EDFZ112	EDUZ110 24V
	Required power supply	24 V DC	24 V DC
	Cable length	1 m to the drive unit	3 m to the drive unit
	Updates	USB interface for firmware and parameter updates	Network interface for firmware and parameter updates
	Power input	16 A	16 A
	Permissible ambient conditions for operation	5 to 40 °C, atmospheric humidity 90%, non-condensing	5 to 40 °C, atmospheric humidity 90%, non-condensing
	Permissible ambient conditions for storage	-10 °C to 45 °C	-10 °C to 45 °C
	Weight	1,7 kg	2,7 kg
	Cable layout	Flexible for the components, PLUG & PLAY	Flexible for the components, PLUG & PLAY
	Assembly	Individual assembly through integrated mounting plate	Individual assembly through integrated mounting plate
	Reverse voltage protection	Integrated into connectors	Integrated into connectors
	Protection grade	IP X4 (splashes of water from all sides, all plugs plugged in)	IP X4 (splashes of water from all sides, all plugs plugged in)

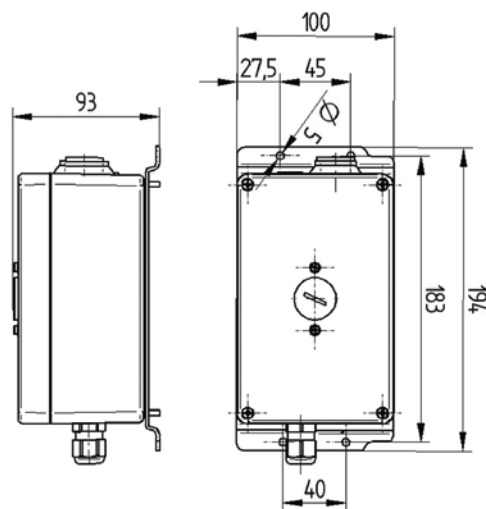

EDFZ112

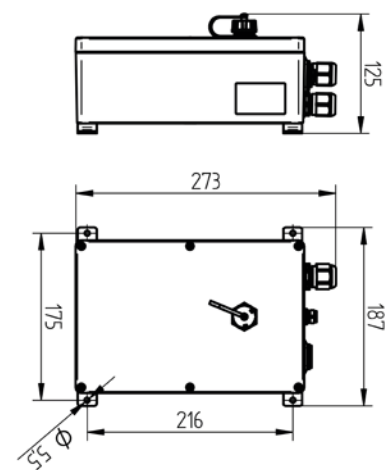

EDUZ110 24V

Handle set



Description	i	Compatible with	E-Drive flex	E-Drive flex and E-Drive ultimate	E-Drive optima
	Article description		EDFZ310 3m	EDMZ310 3m w.emerg.stop cat.0	EDOZ310
	Set components		Two ergonomically designed handles, one with and one without function	Two ergonomically designed handles, one with and one without function	Two ergonomically designed handles, one with and one without function
	Emergency stop button		-	●	-
	Fitting options		For tube fitting from 27 - 35 mm or for fitting on flat surfaces	For tube fitting from 27 - 35 mm or for fitting on flat surfaces	For tube fitting from 27 - 35 mm or for fitting on flat surfaces
	Handle material		Glass-fibre reinforced polyamide	Glass-fibre reinforced polyamide	Glass-fibre reinforced polyamide
	Speed control		Continuously variable, forwards and backwards	Continuously variable, forwards and backwards	Continuously variable, forwards and backwards
	Controller		Safety-tested in accordance with DIN ISO 13849	Safety-tested in accordance with DIN ISO 13849	Safety-tested in accordance with DIN ISO 13849
	Service life of controller		2 million cycles	2 million cycles	2 million cycles
	Controller axle rotation angle		+45° / -45°	+45° / -45°	+45° / -45°
	Positions of thumb depression on controller		Adjustable in 22,5° steps	Adjustable in 22,5° steps	Adjustable in 22,5° steps
	LED-functionality		Shows the status of the drive unit	Shows the status of the drive unit	Shows the status of the drive unit
	Permissible ambient conditions for operation		5 to 50 °C , atmospheric humidity 90%, non-condensing	5 to 50 °C , atmospheric humidity 90%, non-condensing	5 to 50 °C , atmospheric humidity 90%, non-condensing
	Permissible ambient temperature for storage		- 10 to 45 °C	- 10 to 45 °C	- 10 to 45 °C
	Protection type		IPX4 (splash water from all sides) when horizontally mounted	IPX4 (splash water from all sides) when horizontally mounted	IPX4 (splash water from all sides) when horizontally mounted
	Cable length		3 m including plug	3 m including plug	2 m or 3,5 m including plug

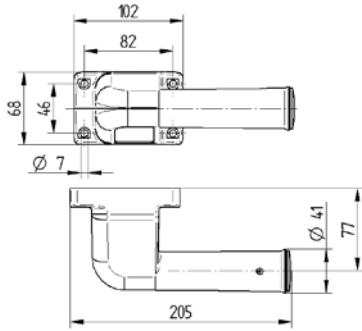

Left handle set without function.

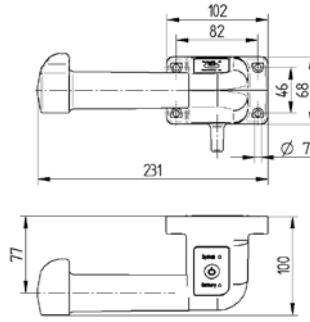

EDUZ300: Right handle set with function.

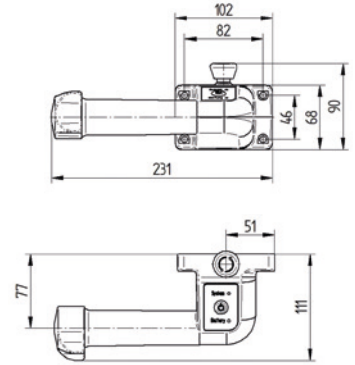

EDFZ300: Right handle set with function and emergency stop switch.

Mounting kits for handles



Description	i		
	Compatible with	E-Drive flex, E-Drive ultimate and E-Drive optima	E-Drive flex, E-Drive ultimate and E-Drive optima
	Article description	EDMZ740 flat surfaces	EDMZ730 D.27-31 EDMZ730 D.31-35
	Fitting type	For even surfaces	For tube fittings
	Material	Aluminium	Aluminium
	Set consists of	4 pieces of clamping blocks	4 pieces clamps, 4 pieces clamping devices, 8 screws M6 × 35
Available for tube-Ø	—	27 - 31 mm 31 - 35 mm	

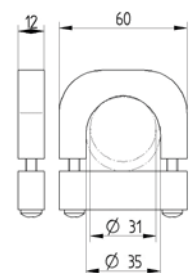
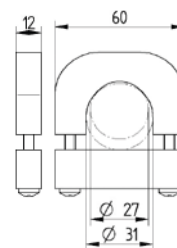
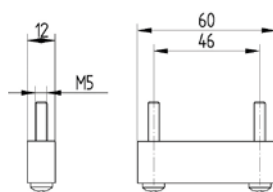

Battery

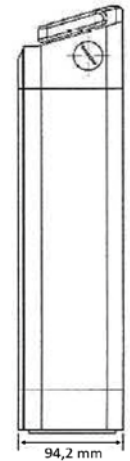
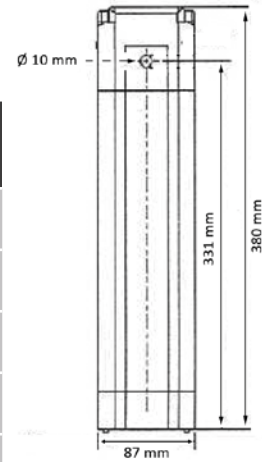

Description	Compatible with	E-Drive flex and E-Drive ultimate	E-Drive flex and E-Drive ultimate	E-Drive optima
	Article description	EDMZ212 10Ah	EDMZ212 15Ah	EDOZ212
	Nominal capacity	10 Ah	15 Ah	11,6 Ah
	Battery type	Lithium-ion battery	Lithium-ion battery	Lithium-ion battery
	Nominal voltage	24 V DC	24 V DC	24 V DC
	Built-in fuse	15 A	15 A	20 A
	Weight	2,4 kg	2,4 kg	2,4 kg
	Measurements	87 x 94,2 x 380 mm (W x D x H)	87 x 94,2 x 380 mm (W x D x H)	87 x 94,2 x 380 mm (W x D x H)
	Connecting plug	Plug-and-play in combination with our battery cable	Plug-and-play in combination with our battery cable	Plug-and-play in combination with our battery cable
	Safety	Key switch to prevent unauthorised use	Key switch to prevent unauthorised use	Key switch to prevent unauthorised use

Battery holder



Description	Compatible with	E-Drive flex, E-Drive optima and E-Drive ultimate
	Article description	EDMZ702
	Fitting	For even and round surfaces
	Material	Steel, powder-coated, light grey RAL 7035
	Set consists of	Battery holder, mounting material and installation guide

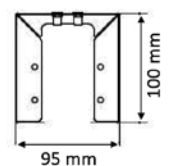
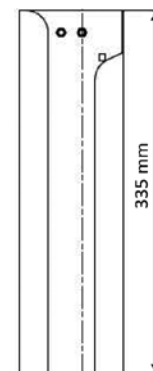

Battery charger



i Description	Compatible with	E-Drive flex and E-Drive ultimate	E-Drive flex and E-Drive ultimate	E-Drive optima
	Article description	EDMZ512 2A	EDMZ512 4A	EDOZ512 2A
	Charging time	For 10 Ah batteries about 5,5 hours For 15 Ah batteries about 8 hours	For 10 Ah batteries about 2,5 hours For 15 Ah batteries about 4 hours	For 11,6 Ah batteries about 6 hours

Battery cable



i Description	Compatible with	E-Drive flex and E-Drive ultimate	E-Drive optima
	Article description	EDMZ412 EDMZ412 2m	EDOZ412
	Length	1 m or 2 m with plug at each end	2 m with plug at each end

Communication cable



i Description	Compatible with	E-Drive flex	E-Drive optima
	Article description	EDFZ413	EDOZ499
	Length	1 m with plug at each end	2 m with plug at each end

Uninterrupted processes
 Uninterrupted use can be guaranteed thanks to the position of the battery, which enables an easy removal.



SET-UP

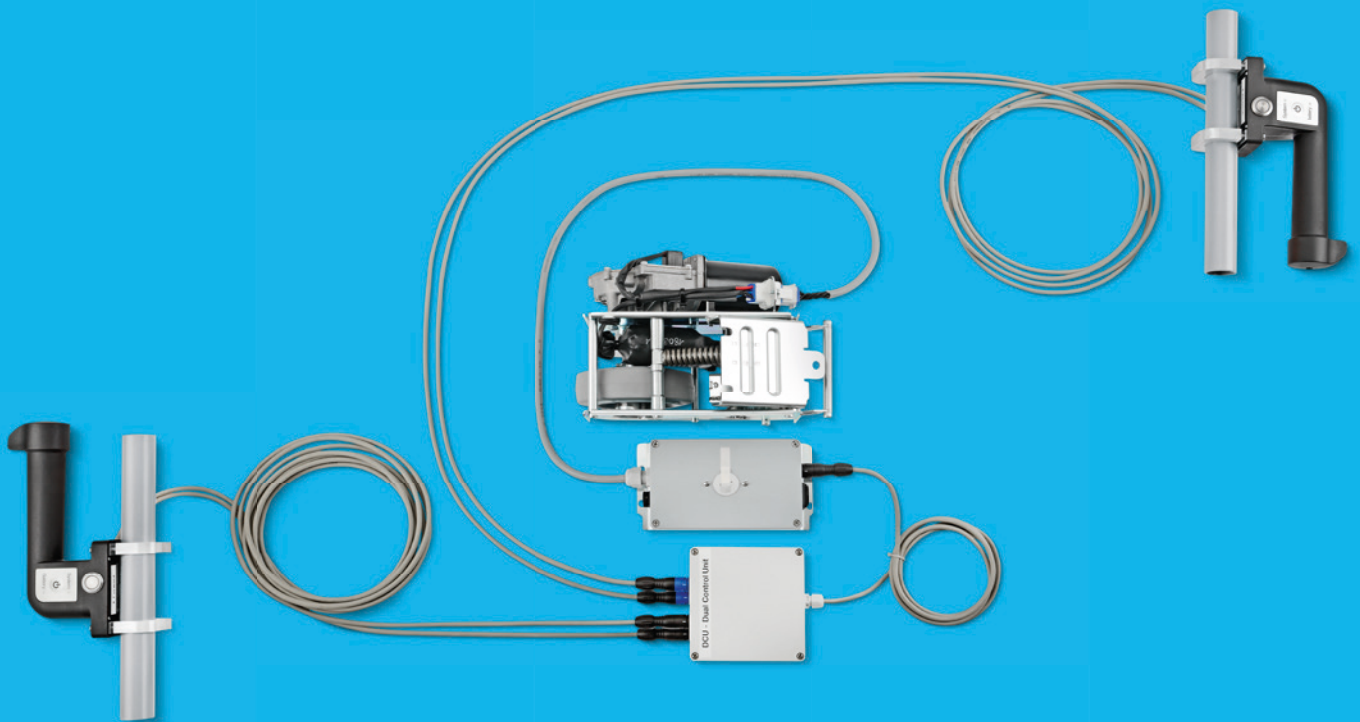

DIFFERENT SET-UPS FOR VARIOUS REQUIREMENTS

Set-Up	Description
Single	Standard set-up which offers all components you need for your application. You are able to move heavy loads. The standard set-up consists of one handle, one battery with charger, one control unit and one drive unit.
Single dual	Sometimes you need to operate your application from two sides, especially when the space around doesn't allow a 360 degree movement. In such cases you can install a handle for steering at both front sides. With a small switch you can activate the handle you want to use.
Twin	You might have transportation processes which are pretty heavy and one single E-Drive set is too weak. You can easily extend your single set-up with doubled drive units. With this twin set you can move loads that are twice as heavy.
Twin dual	Depending on your environment, also with heavy loads you need to operate your application from two sides, especially when the space around doesn't allow a 360 degree movement. In such cases you can install a handle for steering at both front sides. With a small switch you can activate the handle you want to use.

CUSTOMISED SOLUTIONS EXAMPLE

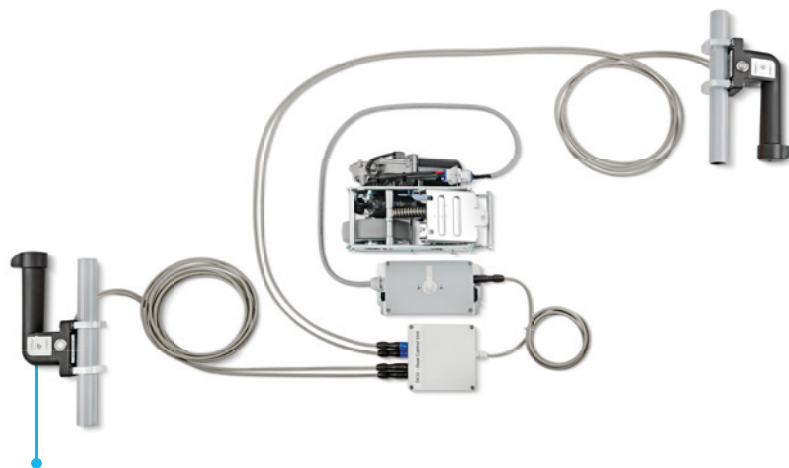

Flexible operation

Integrated set with two handles, enabling the user to push or pull the trolley from both sides to increase efficiency.

DIVERSITY WITH A SYSTEM

OUR CASTORS

All of our products have their own specific qualities and strengths. Whether it's high design standards, specialist applications or exceptional load capacities – our range can meet your needs and can be adapted to fit different models.

From the correct dimensions and technical specifications to the required configuration, our product families are able to offer the ideal solution – whatever you need. Please contact us for more information or visit our website: www.tente.com

E-Drive



⌀ 125 mm

Alpha



⊃ 70 - 500 kg
⌀ 80 - 200 mm

Delta



⊃ 300 - 600 kg
⌀ 125 - 200 mm

Delta twin



⊃ 600 - 750 kg
⌀ 125 - 200 mm

Zeta



⊃ 300 - 800 kg
⌀ 125 - 250 mm

Kappa



⊃ 300 - 3.000 kg
⌀ 80 - 300 mm

Kappa flex



⊃ 360 - 750 kg
⌀ 160 - 200 mm

Omikron



⊃ 900 - 22.500 kg
⌀ 100 - 600 mm

Radiata

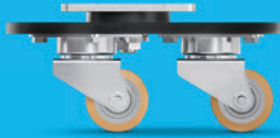

1.200 - 1.500 kg
80 mm

Scout



150 - 350 kg
160 - 200 mm

Integral



100 - 150 kg
100 - 200 mm

Integral twin



125 - 250 kg
100 - 150 mm

Linea clinic



150 - 200 kg
125 - 150 mm

Forma



125 - 150 kg
125 - 150 mm

Aviana care



100 kg
75 mm

Aviana



75 mm

Agila



40 - 100 kg
50 - 150 mm

Agila twin



50 - 100 kg
50 - 75 mm

Stora



60 - 160 kg
75 - 160 mm

Mono



30 - 70 kg
50 - 100 mm

Galea



60 - 100 kg
100 - 125 mm

Levina



60 - 100 kg
75 - 150 mm

Linea



40 - 150 kg
50 - 150 mm

Anika



40 - 50 kg
55 - 75 mm

Lumina



10 - 100 kg
35 - 75 mm

Stylea



40 - 100 kg
35 - 100 mm

Smiles



40 kg
50 mm

Compacta



10 - 55 kg
14 - 50 mm

EXPERTISE THAT INSPIRES

CONTACT US

We are a globally operating company supporting you on five continents. This means on-site support with service on a level playing field – along with in-depth knowledge. Additionally, our solution experts will advise you on the best mobility concept for your needs. Visit our website to find your nearest TENTE location: www.tente.com/locations

INCREASE YOUR EFFICIENCY

Our intelligent mobility solutions help you save time, effort, energy, and operating expenses. This allows you to improve your operating methods and working conditions, thereby optimising your processes and ensuring higher productivity, profitability and safety. Ask for our solutions catalogue or read about how our customers benefit from our tailor-made solutions on our website: www.tente.com/solutions

SAVE DEVELOPMENT TIME

On our website you will also find technical drawings, product data sheets and 2D and 3D CAD files in various formats: www.tente.com/products

GET MORE INFORMATION

In addition to our informative website, you can easily download various catalogues and brochures on mobility solutions, customer references, and much more: www.tente.com/download





www.tente.com



PRODUCTIVITY



SAFETY



DESIGN



DURABILITY



ENVIRONMENT